

### Appearance Change for Inverter Plug-in Options FR-A8ND (E kit), FR-A7ND (E kit), FR-A8NL, and FR-A8NCA

Thank you for your continued patronage of Mitsubishi Electric drive control products.  
 The appearance of the terminal block included with the inverter plug-in options FR-A8ND (E kit), FR-A7ND (E kit), FR-A8NL, and FR-A8NCA will be changed.

#### 1. Products Affected

- FR-A8ND, FR-A8ND E kit
- FR-A7ND, FR-A7ND E kit
- FR-A8NL
- FR-A8NCA

#### 2. Details of Change

The appearance of the terminal block will be changed.  
 The change does not affect the quality, performance, or specifications of the products.

(Example) Appearance of the terminal block

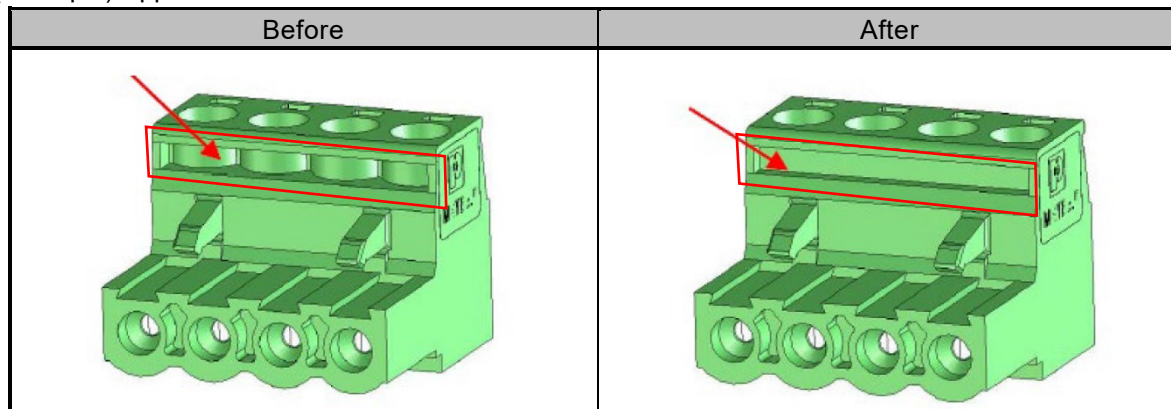

#### 3. Date of Change

The change will be applied to the products manufactured in July 2024 or later.  
 \* Depending on the production condition, the change may not be applied to the products in the beginning of the month of July 2024. In this case, products before and after the change may coexist at the shipment.

<b>Date of issue</b>	June 2024	<b>Title</b>	Appearance Change for Inverter Plug-in Options FR-A8ND (E kit), FR-A7ND (E kit), FR-A8NL, and FR-A8NCA	Mitsubishi Electric Corp., Nagoya Works 5-1-14 Yada-minami, Higashi-ku, Nagoya 461-8670 Tel.: +81 (52) 721-2111 Main line
----------------------	-----------	--------------	--	---

#### 4. Product Identification

The SERIAL (determined by date of production) can be checked on the circuit board or packaging plate of the plug-in option.

SERIAL example on rating plate  
□ 4 7 000  
Symbol Year Month Control number

SERIAL

SERIAL example on packaging plate  
□ 4 7 000  
Symbol Year Month Control number

SERIAL

The SERIAL consists of one symbol, two characters indicating the production year and month, and three characters indicating the control number.

The last digit of the production year is indicated as the Year, and the Month is indicated by 1 to 9, X (October), Y (November), or Z (December).