

Satellite Training Series **PART 2** Your First Inverter

Satellite Training Series



SAFETY PRECAUTIONS

**Always read these precautions
before using this equipment.**

Before designing your system, make sure to read the related manuals of your products to ensure that you exercise appropriate caution with regards to safety. Take the following precautions and use the equipment correctly when practicing and learning the material.

The Mitsubishi general-purpose inverter FR-E700 series is used for this training. If the equipment in your actual environment is different, make sure to read the specific manual for your device as operation methods and parameter type differ depending on the specific model of inverter.

Training precautions

WARNING

- Do not touch the terminals when the power is on to prevent electric shock.
- Before opening the cover, either turn off the power or ensure that it is safe to open the cover.
- Do not insert your hands into moving parts.

This section is specifically about safety matters

Do not attempt to install, operate, maintain or inspect the inverter until you have read through the Instruction Manual and appended documents carefully and can use the equipment correctly. Do not use this product until you have a full knowledge of the equipment, safety information and instructions. In this Instruction Manual, the safety instruction levels are classified into "WARNING" and "CAUTION".

 **WARNING** Incorrect handling may cause hazardous conditions, resulting in death or severe injury.

 **CAUTION** Incorrect handling may cause hazardous conditions, resulting in medium or slight injury, or may cause only material damage.

The  **CAUTION** level may even lead to a serious consequence according to conditions. Both instruction levels must be followed because these are important to personal safety.

1. Electric shock prevention

WARNING

- While power is ON or when the inverter is running, do not open the front cover. Otherwise you may get an electric shock.
- Do not run the inverter with the front cover or wiring cover removed. Otherwise you may access the exposed high voltage terminals or the charging part of the circuitry and get an electric shock.
- Even if power is OFF, do not remove the front cover except for wiring or periodic inspection. You may access the charged inverter circuits and get an electric shock.
- Before wiring or inspection, power must be switched OFF. To confirm that, LED indication of the operation panel must be checked. (It must be OFF.) Any person who is involved in wiring or inspection shall wait for at least 10 minutes after the power supply has been switched OFF and check that there are no residual voltage using a tester or the like. The capacitor is charged with high voltage for some time after power OFF, and it is dangerous.
- This inverter must be earthed (grounded). Earthing (grounding) must conform to the requirements of national and local safety regulations and electrical code (NEC section 250, IEC 536 class 1 and other applicable standards). A neutral-point earthed (grounded) power supply for 400V class inverter in compliance with EN standard must be used.
- Any person who is involved in wiring or inspection of this equipment shall be fully competent to do the work.
- The inverter must be installed before wiring. Otherwise you may get an electric shock or be injured.
- M Dial and key operations must be performed with dry hands to prevent an electric shock. Otherwise you may get an electric shock.
- Do not subject the cables to scratches, excessive stress, heavy loads or pinching. Otherwise you may get an electric shock.
- Do not change the cooling fan while power is ON. It is dangerous to change the cooling fan while power is ON.
- Do not touch the printed circuit board with wet hands. Otherwise you may get an electric shock.
- When measuring the main circuit capacitor capacity, the DC voltage is applied to the motor for 1s at powering OFF. Never touch the motor terminal, etc. right after powering OFF to prevent an electric shock.

2. Fire prevention

CAUTION

- Inverter must be installed on a nonflammable wall without holes (so that nobody touches the inverter heatsink on the rear side, etc.). Mounting it to or near flammable material can cause a fire.
- If the inverter has become faulty, the inverter power must be switched OFF. A continuous flow of large current could cause a fire.
- When using a brake resistor, a sequence that will turn OFF power when a fault signal is output must be configured. Otherwise the brake resistor may excessively overheat due to damage of the brake transistor and such, causing a fire.
- Do not connect a resistor directly to the DC terminals P/+ and N/-. Doing so could cause a fire.

3. Injury prevention

CAUTION

- The voltage applied to each terminal must be the ones specified in the Instruction Manual. Otherwise burst, damage, etc. may occur.
- The cables must be connected to the correct terminals. Otherwise burst, damage, etc. may occur.
- Polarity must be correct. Otherwise burst, damage, etc. may occur.
- While power is ON or for some time after power-OFF, do not touch the inverter as they will be extremely hot. Doing so can cause burns.

4. Additional instructions

Also the following points must be noted to prevent an accidental failure, injury, electric shock, etc.

(1) Transportation and mounting

CAUTION

- The product must be transported in correct method that corresponds to the weight. Failure to do so may lead to injuries.
- Do not stack the boxes containing inverters higher than the number recommended.
- The product must be installed to the position where withstands the weight of the product according to the information in the Instruction Manual.
- Do not install or operate the inverter if it is damaged or has parts missing.
- When carrying the inverter, do not hold it by the front cover or M Dial; it may fall off or fail.
- Do not stand or rest heavy objects on the product.
- The inverter mounting orientation must be correct.
- Foreign conductive bodies must be prevented to enter the inverter. That includes screws and metal fragments or other flammable substance such as oil.
- As the inverter is a precision instrument, do not drop or subject it to impact.
- The inverter must be used under the following environment. Otherwise the inverter may be damaged.

Environment	Surrounding air temperature	-10°C to +50°C (non-freezing) (-10°C to +40°C for totally-enclosed structure feature)
	Ambient humidity	90%RH or less (non-condensing)
	Storage temperature	-20°C to +65°C *1
	Atmosphere	Indoors (free from corrosive gas, flammable gas, oil mist, dust and dirt)
	Altitude/vibration	Maximum 1,000m above sea level. 5.9m/s ² or less at 10 to 55Hz (directions of X, Y, Z axes)

*1 Temperature applicable for a short time, e.g. in transit.

(2) Wiring

CAUTION

- Do not install a power factor correction capacitor or surge suppressor/capacitor type filter on the inverter output side. These devices on the inverter output side may be overheated or burn out.
- The connection orientation of the output cables U, V, W to the motor affects the rotation direction of the motor.

(3) Trial run

CAUTION

- Before starting operation, each parameter must be confirmed and adjusted. A failure to do so may cause some machines to make unexpected motions.

(4) Usage

WARNING

- Any person must stay away from the equipment when the retry function is set as it will restart suddenly after trip.
- Since pressing  key may not stop output depending on the function setting status, separate circuit and switch that make an emergency stop (power OFF, mechanical brake operation for emergency stop, etc.) must be provided.
- OFF status of the start signal must be confirmed before resetting the inverter fault. Resetting inverter alarm with the start signal ON restarts the motor suddenly.
- The inverter must be used for three-phase induction motors. Connection of any other electrical equipment to the inverter output may damage the equipment.
- Do not modify the equipment.
- Do not perform parts removal which is not instructed in this manual. Doing so may lead to fault or damage of the product.

CAUTION

- The electronic thermal O/L relay function does not guarantee protection of the motor from overheating. It is recommended to install both an external thermal and PTC thermistor for overheat protection.
- Do not use a magnetic contactor on the inverter input for frequent starting/stopping of the inverter. Otherwise the life of the inverter decreases.
- The effect of electromagnetic interference must be reduced by using a noise filter or by other means. Otherwise nearby electronic equipment may be affected.
- Appropriate measures must be taken to suppress harmonics. Otherwise power supply harmonics from the inverter may heat/damage the power factor correction capacitor and generator.
- When driving a 400V class motor by the inverter, the motor must be an insulation-enhanced motor or measures must be taken to suppress surge voltage. Surge voltage attributable to the wiring constants may occur at the motor terminals, deteriorating the insulation of the motor.
- When parameter clear or all parameter clear is performed, the required parameters must be set again before starting operations because all parameters return to the initial value.

CAUTION

- The inverter can be easily set for high-speed operation. Before changing its setting, the performances of the motor and machine must be fully examined.
- Stop status cannot be hold by the inverter's brake function. In addition to the inverter's brake function, a holding device must be installed to ensure safety.
- Before running an inverter which had been stored for a long period, inspection and test operation must be performed.
- For prevention of damage due to static electricity, nearby metal must be touched before touching this product to eliminate static electricity from your body.
- If you are installing the inverter to drive a three-phase device while you are contracted for lighting and power service, consult your electric power supplier.

(5) Emergency stop

CAUTION

- A safety backup such as an emergency brake must be provided to prevent hazardous condition to the machine and equipment in case of inverter failure.
- When the breaker on the inverter input side trips, the wiring must be checked for fault (short circuit), and internal parts of the inverter for a damage, etc. The cause of the trip must be identified and removed before turning ON the power of the breaker.
- When any protection function is activated, appropriate corrective action must be taken, and the inverter must be reset before resuming operation.

(6) Maintenance, inspection and parts replacement

CAUTION

- Do not carry out a megger (insulation resistance) test on the control circuit of the inverter. It will cause a failure.

(7) Disposal

CAUTION

- The inverter must be treated as industrial waste.

General instruction

Many of the diagrams and drawings in this Instruction Manual show the inverter without a cover or partially open for explanation. Never operate the inverter in this manner. The cover must be always re-installed and the instruction in this Instruction Manual must be followed when operating the inverter.

Introduction

This document covers some fundamentals of inverters that first-time users of inverters should know.

This document was created on the premise that the Mitsubishi general-purpose inverter FR-E700 series would be used for training.

Before wiring your inverter, make sure to read the related manuals of your products to ensure that you exercise appropriate caution with regards to safety.

The following table lists some related documentation.

Manual name	Manual number	Description
Inverter FREQROL-E700 Instruction Manual (Basic Edition)	IB-0600441ENG	Excerpts from E700 usage precautions and the parameter list
Inverter FREQROL-E700 Instruction Manual (Practical Use Edition)	IB-0600277ENG	Excerpts from E700 specifications, wiring, and installation
Inverter setup software FR Configurator SW 3 Instruction Manual	IB-0600306ENG	Excerpts from content regarding starting the inverter setup
GOT2000 series Connection Manual (Connecting with Mitsubishi Devices Edition)	SH-081197ENG	Excerpts from content regarding connections between the inverter and GOT

Trademarks

- Windows®, Windows 7®, and Windows 8® are trademarks and registered trademarks in the United States and other countries of Microsoft Corporation.
- Other company names or product names are trademarks or registered trademarks of their respective companies.

This manual confers no industrial property rights or any rights of any other kind, nor does it confer any patent licenses.

Mitsubishi Electric Corporation shall not be held responsible for any problems involving industrial property rights which may occur as a result of using the content described in this manual.

Contents

Chapter 1 Brief description of inverters	1-1
1.1 What is an inverter?.....	1-2
1.1.1 Basic functions of the inverter.....	1-2
1.1.2 Benefits of the inverter.....	1-2
1.1.3 Familiar examples where inverters are used.....	1-3
1.2 Motor drive force.....	1-6
1.2.1 Motor and frequency.....	1-6
1.2.2 Principles of the motor.....	1-7
1.3 Changing frequency.....	1-8
1.3.1 Structure of the inverter.....	1-8
Chapter 2 Specific models of the inverter	2-1
2.1 Mitsubishi general-purpose inverters.....	2-2
2.1.1 Lineup.....	2-2
2.2 Detailed description of the inverter.....	2-5
2.2.1 Parts identification for the Mitsubishi general-purpose inverter FR-E700 series.....	2-5
2.3 Connecting the inverter.....	2-6
2.3.1 Removing and installing the cover.....	2-6
2.3.2 Connecting the power cable.....	2-7
2.3.3 Control terminals.....	2-8
2.4 Inverter usage precautions.....	2-10
2.4.1 Installation of the inverter.....	2-10
2.4.2 Troubleshooting.....	2-13
Chapter 3 Parameters	3-1
3.1 Setting basic parameters.....	3-2
3.1.1 Brief description of parameters.....	3-2
3.1.2 Typical parameters.....	3-2
3.2 Operation panel.....	3-3
3.2.1 Names and functions of the operation panel.....	3-3
3.3 Selecting the operation mode and command source.....	3-4
3.3.1 Various operation modes.....	3-4
3.3.2 Operation mode selection (Pr. 79).....	3-5
3.4 Basic operation modes.....	3-6
3.4.1 External operation mode.....	3-6
3.4.2 PU operation mode.....	3-6
3.4.3 External/PU operation mode 1.....	3-7
3.4.4 External/PU operation mode 2.....	3-7

1

2

3

4

5

6

Appendix

3.5	How to configure parameters.....	3-8
3.5.1	Parameter clear/All parameter clear	3-8
3.5.2	Pr. 9 Electronic thermal O/L relay	3-9
3.5.3	Pr. 3 Base frequency.....	3-10
3.5.4	Pr. 0 Torque boost.....	3-11
3.5.5	Pr. 1, 2 Upper-limit/lower-limit frequency	3-12
3.5.6	Pr. 7, 8 Acceleration/deceleration time.....	3-13

Chapter 4	How to use FR Configurator	4-1
------------------	-----------------------------------	------------

4.1	Fundamental knowledge to operate FR Configurator.....	4-2
4.1.1	Items needed for connectivity	4-2
4.1.2	Connection method.....	4-2
4.1.3	Startup	4-3
4.1.4	Screen configuration (Main frame).....	4-4
4.1.5	Screen configuration (Navigation area)	4-5
4.1.6	Screen configuration (System area)	4-6
4.1.7	Screen configuration (Monitor area)	4-7
4.2	Easy Setup	4-8
4.2.1	Configuration method.....	4-8
4.2.2	System property.....	4-9
4.2.3	Communication setting	4-10
4.2.4	Inverter setting method	4-11
4.2.5	Automatic detection.....	4-12
4.2.6	Inverter selection.....	4-13
4.2.7	Control method	4-14
4.2.8	Motor setting	4-15
4.2.9	Start command and frequency (speed) setting method	4-16
4.2.10	Parameter List.....	4-17
4.3	Parameter List operations.....	4-18
4.3.1	Parameter List functions	4-18
4.3.2	Read (Batch Read), write (Batch Write) and verification	4-19
4.3.3	Parameter clear and all parameter clear.....	4-20

Chapter 5	Inverter external connections	5-1
------------------	--------------------------------------	------------

5.1	Connecting GOT with the inverter	5-2
5.1.1	Function overview	5-2
5.1.2	System configuration	5-2
5.1.3	Cable connection diagram	5-3
5.1.4	Inverter communication settings	5-4
5.1.5	GOT communication settings.....	5-5

5.2	Connecting MELSEC iQ-F series with the inverter.....	5-7
5.2.1	Function overview	5-7
5.2.2	System configuration	5-8
5.2.3	Connecting terminating resistors	5-10
5.2.4	Cable wiring diagram	5-11
5.2.5	Inverter communication settings	5-13
5.2.6	FX5 programmable controller communication settings.....	5-14
5.3	External potentiometer operation.....	5-15
5.3.1	Analog configuration of frequency (voltage and current input)	5-15

Chapter 6 Review	6-1
-------------------------	------------

Review 1	Belt conveyor control	6-2
Review 2	Writing parameters using FR Configurator	6-3
Review 3	Comprehension test.....	6-4

Appendix

Appendix 1	Parameter List (FR-E700).....	App.1-1
Appendix 2	List of fault displays (FR-E700).....	App.2-1
Appendix 3	Final assembly of training devices.....	App.3-1
Appendix 4	Terminal connection diagram (FR-E700).....	App.4-1

MEMO

Chapter 1

Brief description of inverters

Inverter basics

As we will cover in more detail throughout this document, "inverters" are devices used to control motor speed.

While this is not a term often heard in typical conversation, inverters are used in many of the devices used on a daily basis.

Inverters are used in trains, for example. "Inverters" control the speed of motors in trains to control the speed of the train itself to ensure safe operation.

This chapter describes the fundamentals of "inverters".

1.1 What is an inverter?

1.1.1 Basic functions of the inverter

© Inverter

Motors are used to operate many of the devices and products we use on a daily basis.

The reason devices do not suddenly start to operate when power switches are turned on is because the inverter controls the speed of motors.

In basic terms, the inverter is a **device that changes the speed of standard motors without restriction.**

1.1.2 Benefits of the inverter

- 1** The inverter can freely changes the speed of standard motors. They can be also connected to the already-installed standard motors.
- 2** The inverter can drive standard motors at a set speed regardless the power supply frequency.
- 3** The inverter can save energy (electricity).
- 4** The inverter can improve productivity by changing the standard motor speed to match the application.
- 5** The inverter can perform smooth start and stop operations by reducing the starting current of standard motors.

1.1.3 Familiar examples where inverters are used

Belt conveyors used in factories

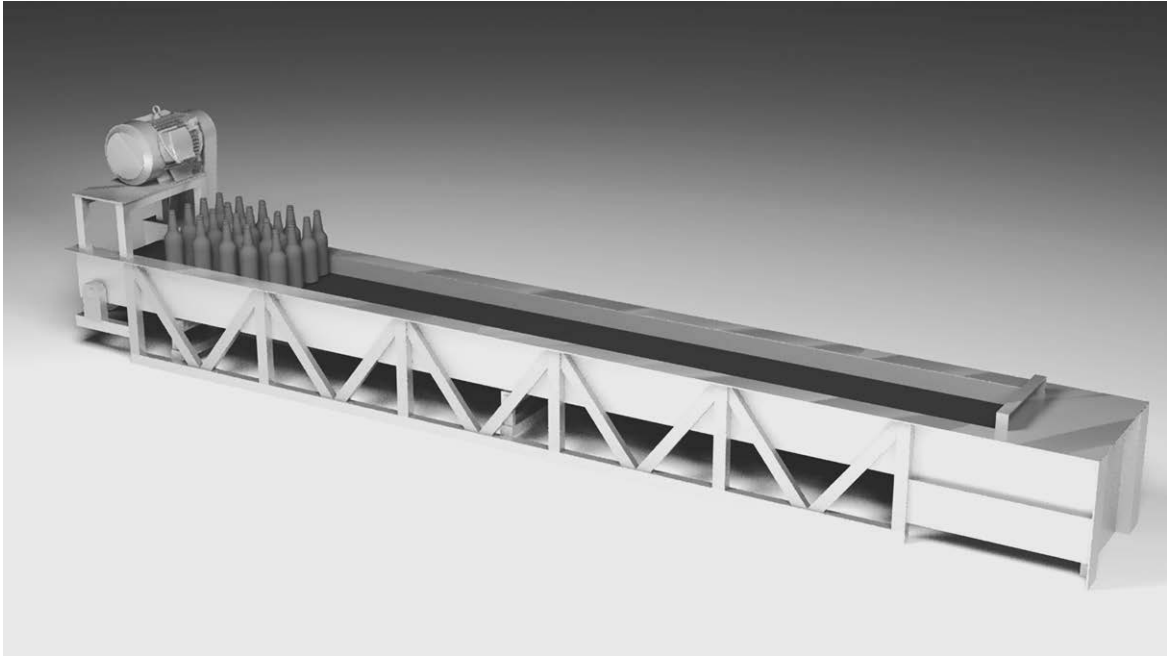

☆ Improve efficiency of work, braking at specific positions, automatic operation

- The inverter improves efficiency of work and enable conveyors to be stopped at specific positions.
- Conveyor speeds can be optimally adjusted depending on the work conditions.
- Soft starts and stops prevent products from moving around and falling off the conveyor.
- Conveyor acceleration and deceleration can be controlled such that shock to machines is reduced or removed completely.

Ventilation fans used in buildings

- Pump
- Fan, blower
- Ventilation fan
- Cooling tower
- Drying machine (Furnace fan)

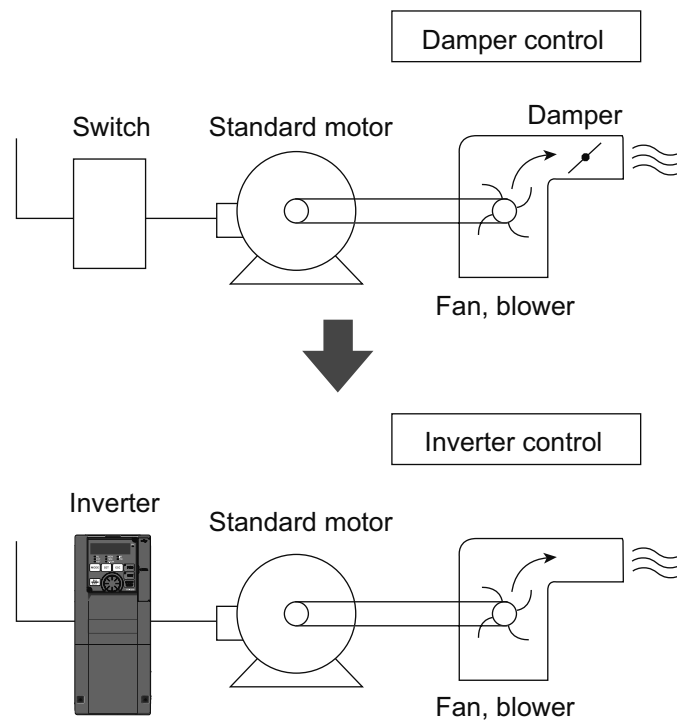

☆ **The inverter achieves energy efficiency and automation.**

- Useful for air flow control (flow amount control)
- Automatic control over air flow (pressure or flow amount)
- Necessary amount can be changed according to seasons and day/night.

Inverters are used in these and many other applications.



• Air conditioner

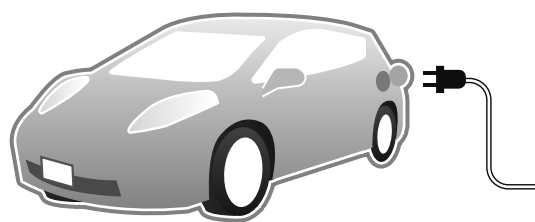

• Electric vehicle

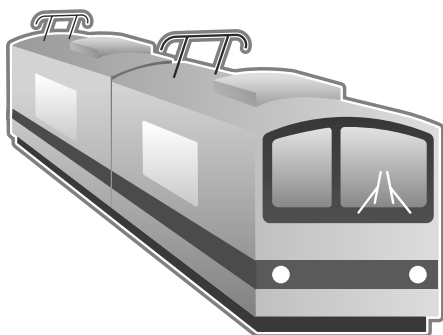

• Train



• Washing machine

As you can see, inverters are used in the products and devices we use every day.

1.2 Motor drive force

1.2.1 Motor and frequency

Motor speed is changed by varying the frequency of current flowing through motors. Frequency is discussed in more detail in this section.

◎ Frequency

Outlets in homes, for example, supply power at 100V/50Hz and 200V/60Hz specifications.

"V" represents voltage and "Hz" represents the frequency.

Frequency values are usually shown in a graph like this. For example, frequency 60Hz means that there are 60 waves between positive and negative per second.

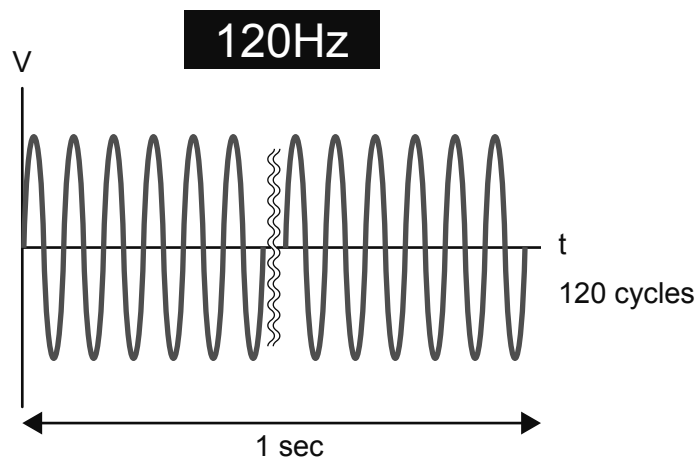
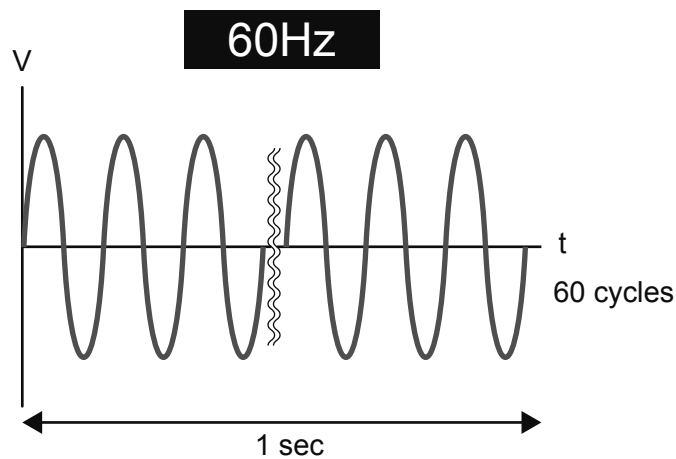

1.2.2 Principles of the motor

When a motor is connected to a source of power, current flows through the stator winding, or stator coil, within the motor, which creates a rotating magnetic field. This rotating magnetic field causes the stator (rotor) to rotate. Motor speed is proportional to the frequency of the power source. Basically, the motor rotates by electromagnetic force.

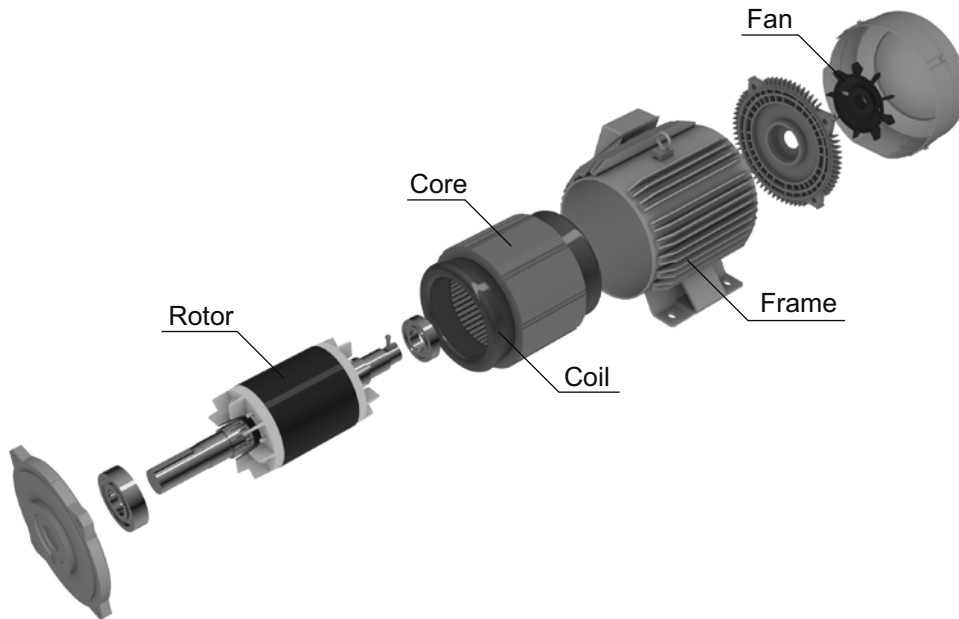

Structure of the motor

1.3 Changing frequency

1.3.1 Structure of the inverter

The inverter is generally comprised of 3 sections: converter section, inverter section, and control circuit.

☉ Converter section

The converter section converts an AC of an AC power supply into a DC, and then smooths out the pulses of current by the smoothing capacitor.

☉ Inverter section

The inverter section converts the DC converted by the converter section into a pulsed current of alternating current having variable frequency.

* Pulsed current refers to current that flows intermittently for short periods of time.

☉ Control circuit

The control circuit controls the converter and inverter sections.

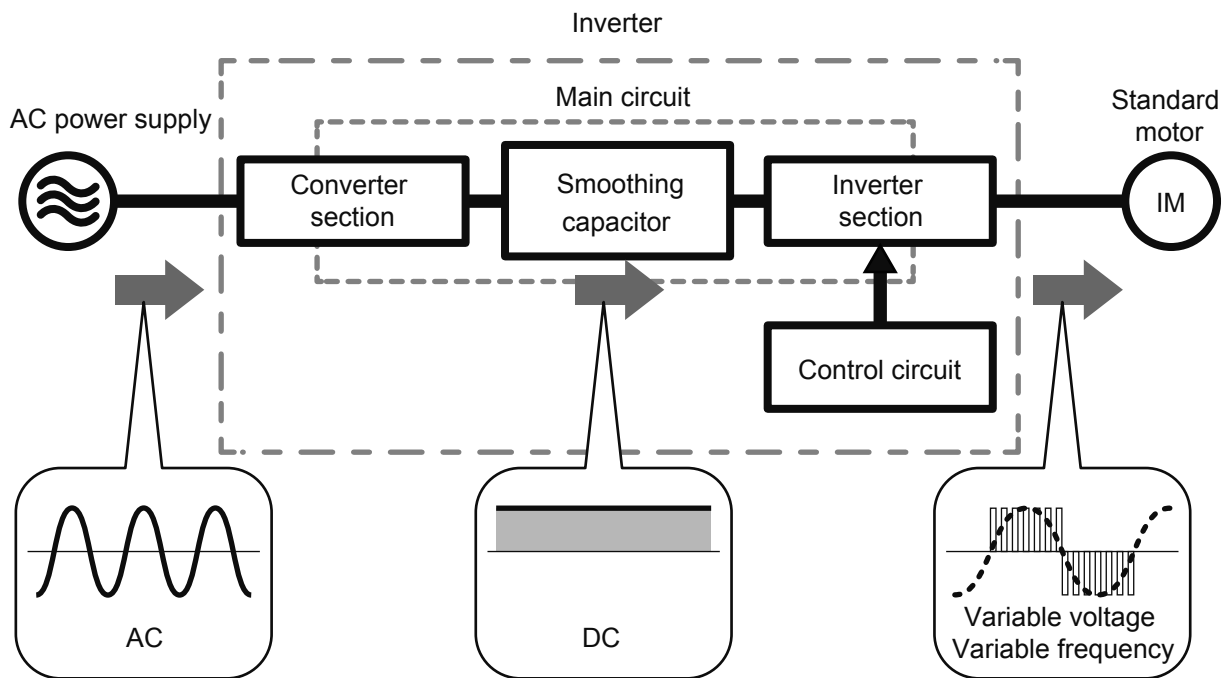

Chapter 2

Specific models of the inverter

Mitsubishi general-purpose inverters

This chapter introduces several types of actual "inverters".

Mitsubishi offers many types of inverters to suit different purposes.

This chapter will cover the compact and high functionality FR-E700 model in detail.

Make sure the power is not turned on before connecting the power cable.

2.1 Mitsubishi general-purpose inverters

2.1.1 Lineup

Inverter line-up

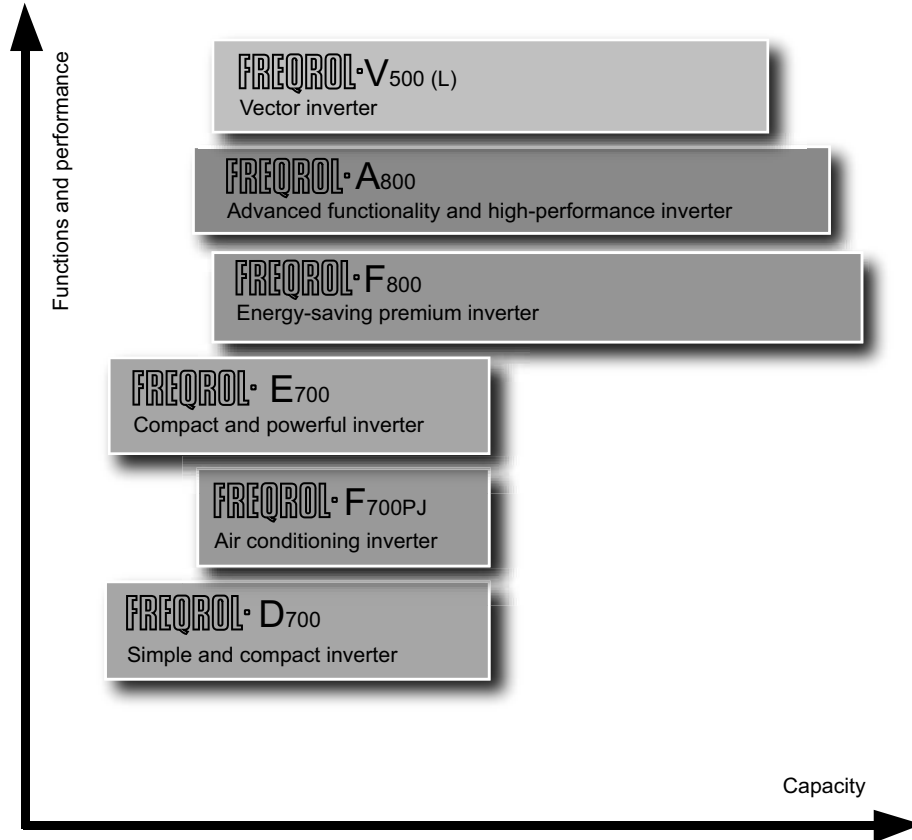

Applicable series for each industry

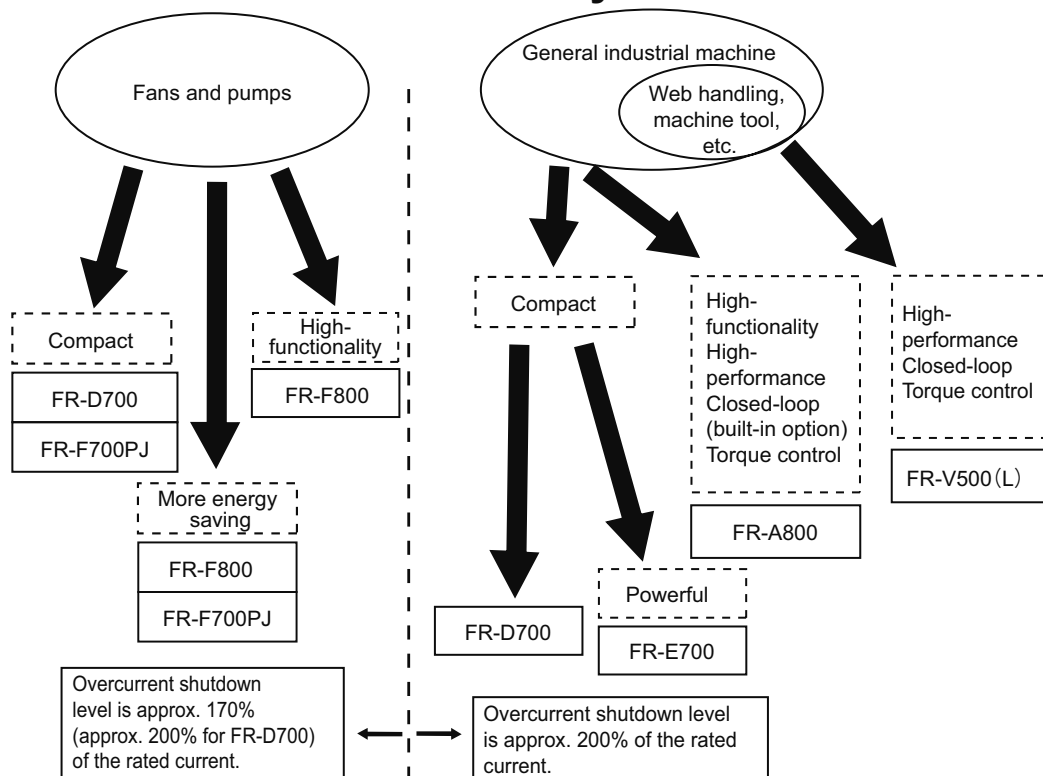

For fans and pumps

FR-F800



Three-phase 200V class	0.75K to 110K
Three-phase 400V class	0.75K to 560K

- Drives both the general-purpose motors and IPM motors. When it drives an IPM motor (MM-EFS), which has permanent magnets embedded in its rotor, energy savings and high efficiency can be further achieved.
- This inverter is suitable for fans and pumps, and has the various functions: optimum excitation control, variable torque acceleration/deceleration patterns, PID control, commercial power supply switching, adjustable 5 points V/F, continuous operation at an instantaneous power failure, regeneration avoidance function, etc.
- Service life of parts is extended. It comes with the service life diagnose function as standard.
- Compatible with various plug-in options.
Compatible with networks, such as LONWORKS and CC-Link, via plug-in options.

FR-F700PJ



Three-phase 200V class	0.4K to 15K
Three-phase 400V class	0.4K to 15K

- Drives both the general-purpose motors and IPM motors. When it drives an IPM motor (MM-EFS), which has permanent magnets embedded in its rotor, the energy saving and high efficiency can be further achieved.
- Spring clamp terminals provide high reliability and easy wiring.

MM-EFS (75kW or less)
MM-THE4 (75kW or more)



Three-phase 200V class	0.75kW to 55kW (75kW is to be released soon.)
Three-phase 400V class	0.75kW to 55kW (75kW to 160kW are to be released soon.)

- This is an IPM motor, which has permanent magnets embedded in its rotor. It is more efficient than an induction motor.
- Compared with the "MM-EF series", the motor loss (iron loss and primary copper loss) is further reduced, and thus achieving higher efficiency. This motor satisfies the highest efficiency standard IE4 (super premium efficiency).

SF-PR



Three-phase 200V class	0.75kW to 55kW
Three-phase 400V class	0.75kW to 55kW

- This model achieves the IE3 efficiency class with the same dimensions as those of conventional models using our unique steel plate frame technology and new core materials.
- It maintains interchangeability with our standard-efficiency motor SF-JR for easy replacement.

General industrial applications

(Suitable for transfer, conveyor, food packaging, and standard machine tools, etc.)

FR-E700

Single-phase 100V class	0.1K to 0.75K	Three-phase 200V class	0.1K to 15K
Single-phase 200V class	0.1K to 2.2K	Three-phase 400V class	0.4K to 15K



- 0.5Hz 200% torque (0.1K to 3.7K) can be generated under Advanced magnetic flux vector control.
- The non-slip M Dial with adaptive stroke speed allows for quick jumps or precise increments based on turning speed.
- Compatible with various plug-in options.
The inverter is compatible with networks, such as CC-Link, PROFIBUS-DP, DeviceNet, via plug-in options.

General industrial applications

(Suitable for transfer, conveyor, food packaging, fans and pumps, etc.)

FR-D700

Single-phase 100V class	0.1K to 0.75K	Three-phase 200V class	0.1K to 15K
Single-phase 200V class	0.1K to 2.2K	Three-phase 400V class	0.4K to 15K



- Spring clamp terminals provide high reliability and easy wiring.
- It features the safety stop function and can comply with safety standards at a low cost.
- 1Hz 150% torque can be generated under General-purpose magnetic flux and with the auto tuning function.
- The non-slip M Dial with adaptive scroll speed allows for quick jumps or precise increments based on turning speed.

General industrial applications

(Suitable for lift, web line control, machine tools, etc.)

FR-A800

Three-phase 200V class	0.4K to 90K
Three-phase 400V class	0.4K to 500K



- PM sensorless vector control enables combinations with PM (magnetic) motor. The auto-tuning function enables operation of other manufacturers' PM motors.
- Many useful features such as USB memory connectivity and PLC function
- True vector control possible through combinations with PLG motors (requires the FR-A8AP internal option)
- Compatible with various plug-in options.
Also compatible with networks, such as CC-Link and SSCNET III/H, via plug-in options.

FR-V500 (L)

Three-phase 200V class	1.5 to 55K, 75K
Three-phase 400V class	1.5 to 55K and 75 to 250K



- High-performance and quick-response operation via vector control of specialized motors
- Improved torque precision through high-precision calculations of internal motor magnetic flux
- Adjustment-free speed control gain and position loop gain
- Compatible with operation over SSCNET communication via internal options

2.2 Detailed description of the inverter

2.2.1 Parts identification for the Mitsubishi general-purpose inverter FR-E700 series

- Inverter model

FR - **E720** - **1.5** K

No.	Voltage class
E720	Three-phase 200V class
E740	Three-phase 400V class
E720S	Single-phase 200V class
E710W	Single-phase 100V class

Represents the inverter capacity [kW]

Symbol	Control circuit terminal specification
None	Standard control circuit terminal (screw plug)
SC	Models equipped with Safety Stop functionality
NF	Models equipped with FL remote communication functionality
NC	Models equipped with CC-Link communication functionality

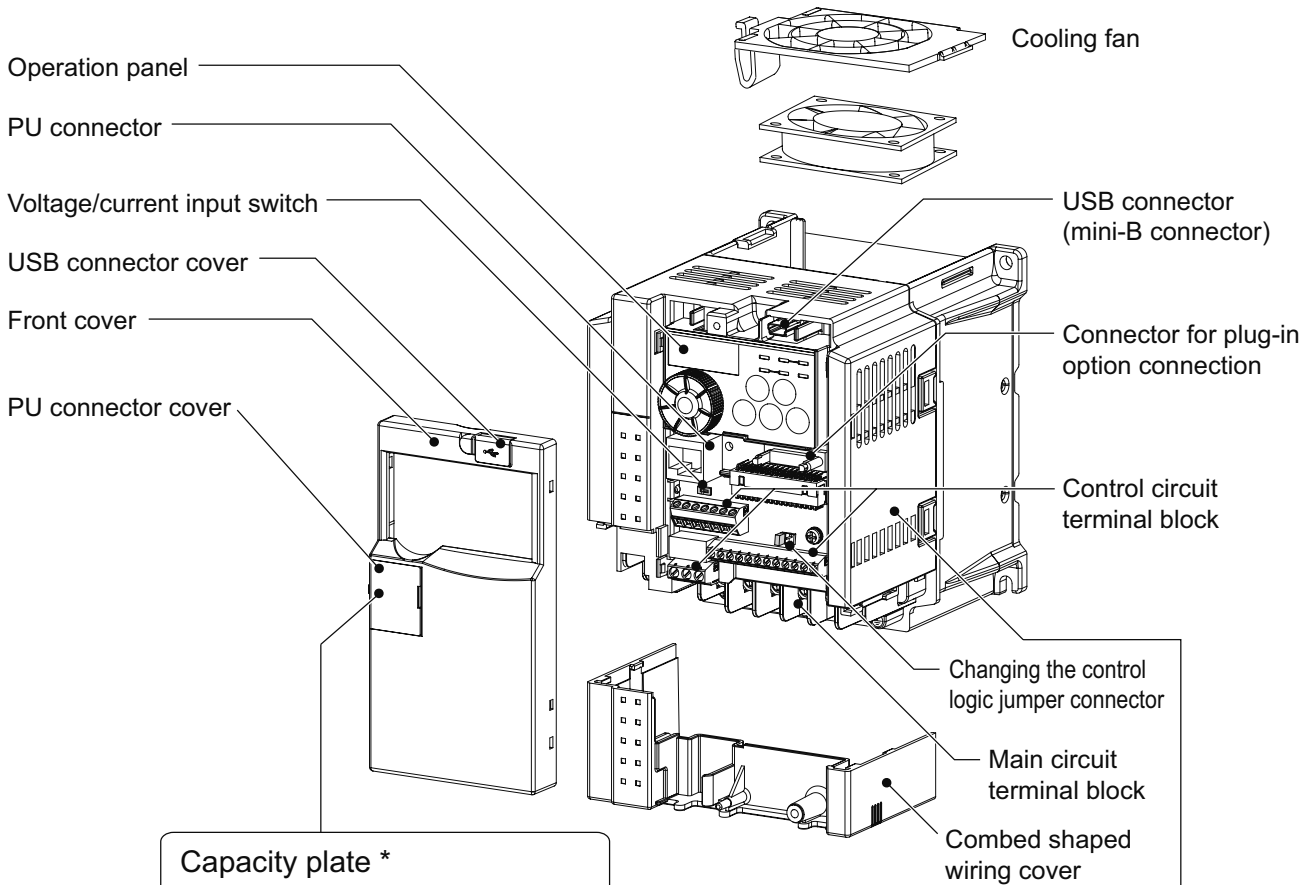

Capacity plate *
FR-E720-1.5K ← Inverter model
 SERIAL: **XXXXXX** ← Serial number

* Location of the capacity plate and the rating plate differs according to the inverter capacity. Refer to the outline dimension drawing.

Rating plate *

Inverter model	MODEL	FR-E720-1.5K
Input rating	INPUT	: XXXXX
Output rating	OUTPUT	: XXXXX
Serial number	SERIAL	:

INVERTER
 PASSED
 MITSUBISHI ELECTRIC CORPORATION
 MADE IN JAPAN

- Accessory

Fan cover fixing screws (M3 × 35mm)

2.3 Connecting the inverter

2.3.1 Removing and installing the cover

Removal

Remove the front cover by pulling it toward you in the direction of arrow.

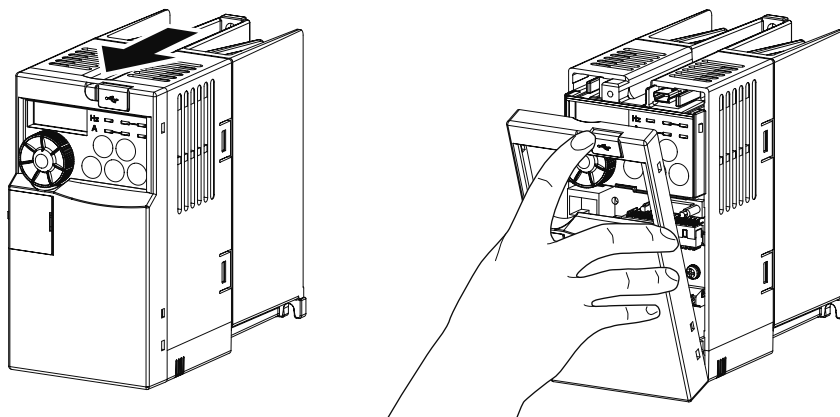

Reinstallation

To reinstall, match the cover to the inverter front and install it straight.

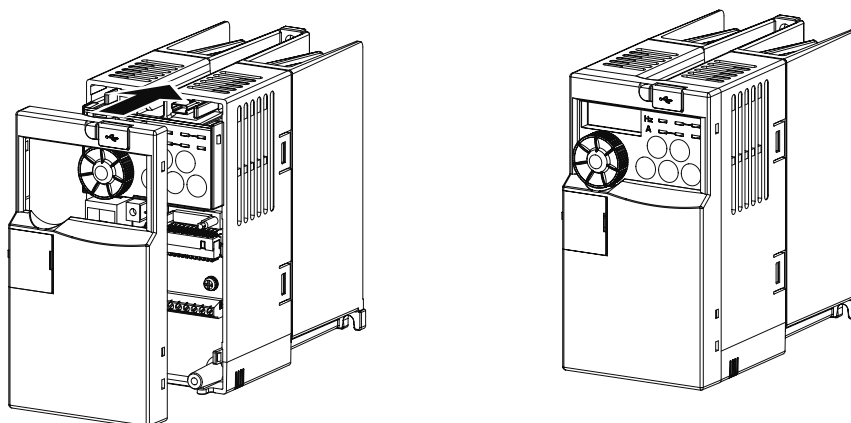

Wiring cover

Removes easily when pulled toward the front. Install the cover to the unit in alignment with the guide.

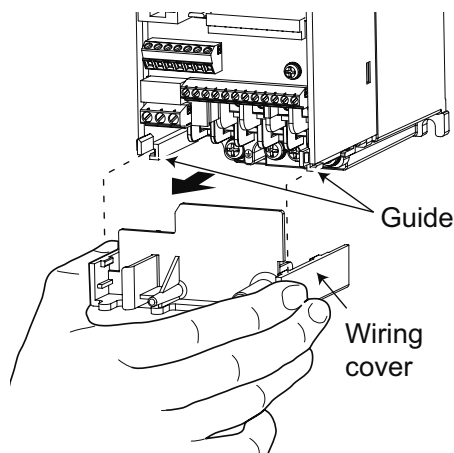

2.3.2 Connecting the power cable

There are two types of power cables that can be used to connect to the inverter.

*Either the single-phase input type or three-phase input type cable is used depending on your power supply.

The single-phase input type is also further separated in 200V and 100V inputs. The output in either case is three-phase at 200V.

Single-phase two-wire power supply

This power supply is used for home electric appliances and small electric equipment.

The power supply is connected to the main circuit terminals R and S, and the motor is connected to terminals U, V, and W.

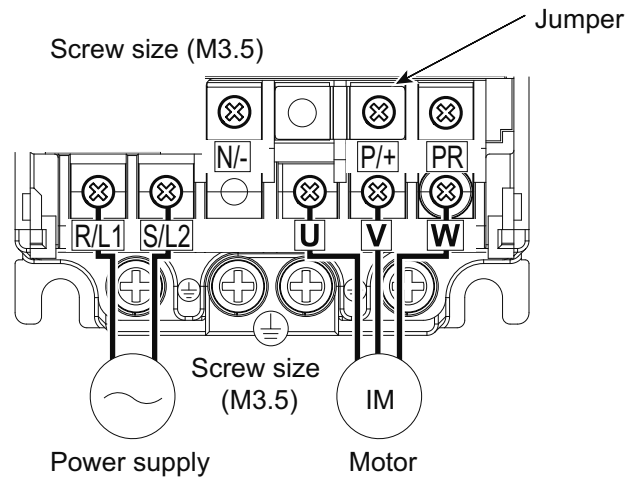

Three-phase three-wire power supply

This power supply is for large electric equipment in factories.

The power supply is connected to the main circuit terminals R, S, and T, and the motor is connected to terminals U, V, and W.

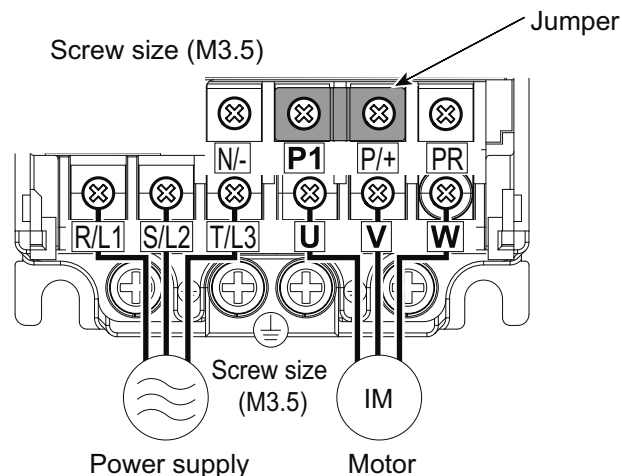

CAUTION

- Make sure the power cables are connected to the R/L1, S/L2, and T/L3 terminals. (Phase need not be matched.) Never connect the power cable to the U, V, and W terminals on the inverter. Doing so will damage the inverter.
- Do not touch the main circuit terminals directly as this could cause electric shock.

2.3.3 Control terminals

Terminal layout

Terminal screw size

M3: (Terminals A, B, and C)

M2: (All others)

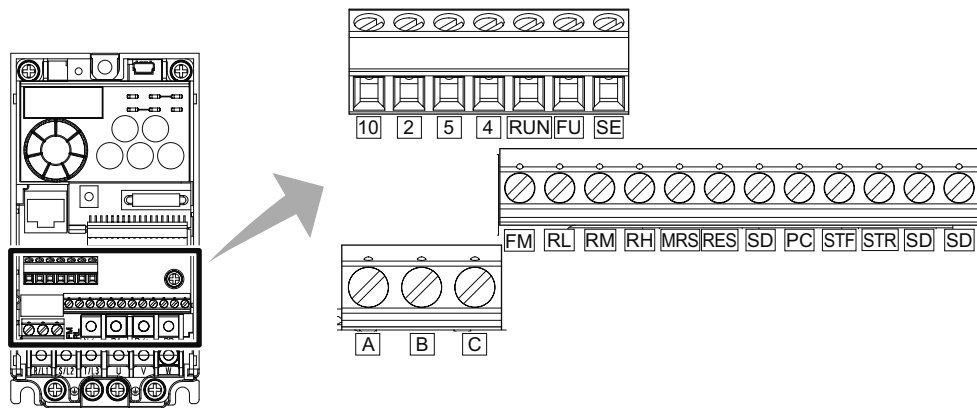

Wiring method

- For the control circuit wiring, strip off the sheath of a cable and use as it is. Strip off the sheath about the size below. If the length of the sheath peeled is too long, a short circuit may occur among neighboring wires. If the length is too short, wires might come off. Wire the stripped wire after twisting it to prevent it from becoming loose. In addition, do not solder it.

Cable sheath stripping length

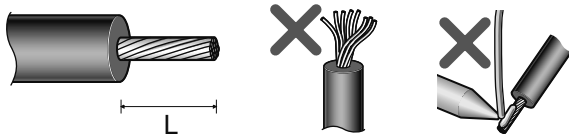

	L (mm)
Terminals A, B, and C	6
All others	5

- Loosen the terminal screw and insert the cable into the terminal.
- Tighten the screw according to the specified tightening torque. Under tightening may cause cable disconnection or malfunction. Over tightening may cause a short circuit or malfunction due to damage to the screw or unit.
Tightening torque: 0.5N m to 0.6N m (terminals A, B, and C),
0.22N m to 0.25N m (terminals other than described above)
Screwdriver: small, ⊖ flat-blade screwdriver (tip thickness: 0.4mm/tip width: 2.5mm)

• Blade terminals

Strip the sheath off of wires, and connect them to a blade terminal.

1. Strip off the sheath about the size below. If the length of the sheath peeled is too long, a short circuit may occur among neighboring wires. If the length is too short, wires might come off. Wire the stripped wire after twisting it to prevent it from becoming loose. In addition, do not solder it.

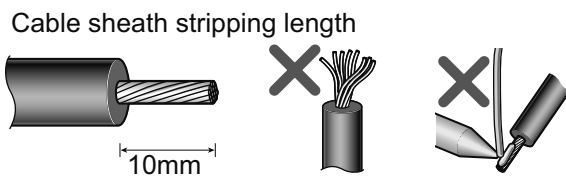

2. Crimp the blade terminal.

Insert wires to a blade terminal, and check that the wires come out for about 0 to 0.5mm from a sleeve. Check the condition of the blade terminal after crimping. Do not use a blade terminal of which the crimping is inappropriate, or the face is damaged.

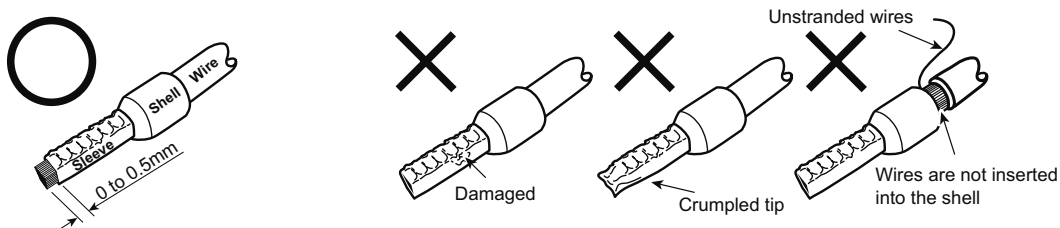

CAUTION

- When using stranded wires without a blade terminal, twist enough to avoid short circuit with a nearby terminals or wires.
- Place the flathead screwdriver vertical to the open/close button. In case the blade tip slips, it may cause an inverter damage or injury.

2.4 Inverter usage precautions

2.4.1 Installation of the inverter

Enclosure surface mounting

Remove the front cover and wiring cover to fix the inverter to the surface.

●FR-E720-0.1K (SC) - 0.75K (SC)

●FR-E720S-0.1K (SC) - 0.4K (SC)

●FR-E710W-0.1K - 0.4K

●FR-E720-1.5K (SC) or later

●FR-E740-0.4K (SC) or later

●FR-E720S-0.75K (SC) or later

●FR-E710W-0.75K

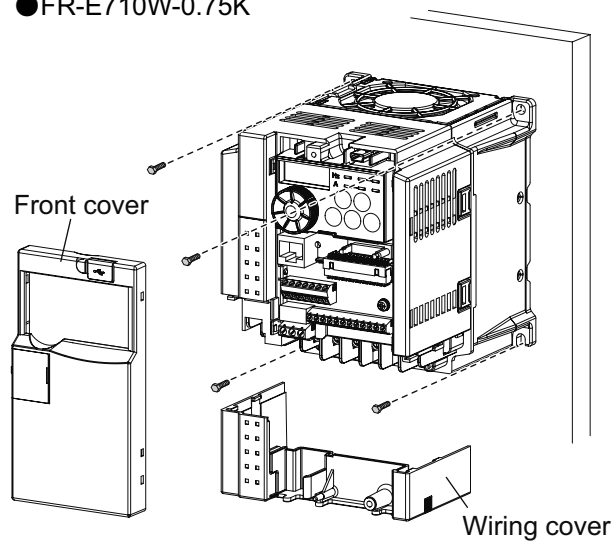
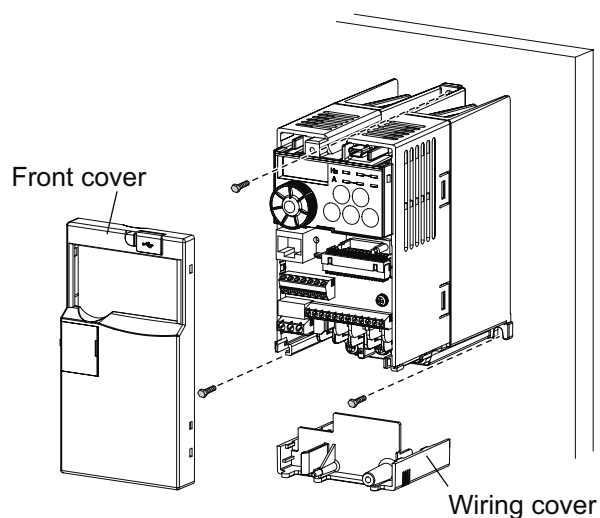

Install the inverter vertically.

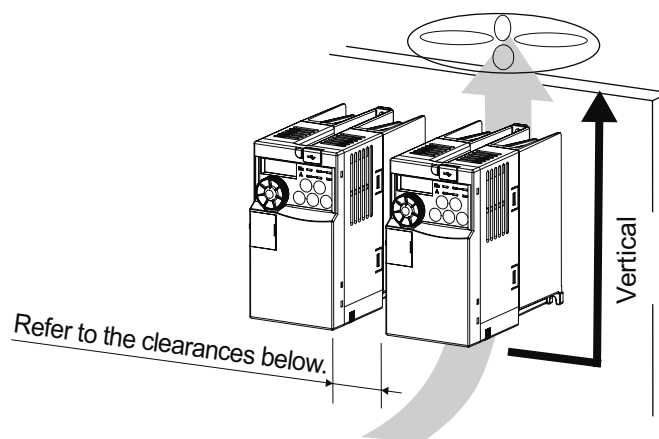

Installation orientation of the inverter

Install the inverter on a wall as specified. Do not mount it horizontally or in any other way.

Clearance around the inverter

To ensure ease of heat dissipation and maintenance, leave at least the shown clearances around the inverter. At least the following clearances are required under the inverter as a wiring space, and above the inverter as a heat dissipation space.

Surrounding air temperature and humidity

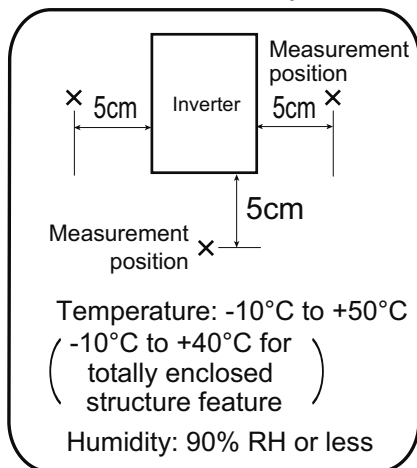

Leave enough clearances and take cooling measures.

Clearances (front)

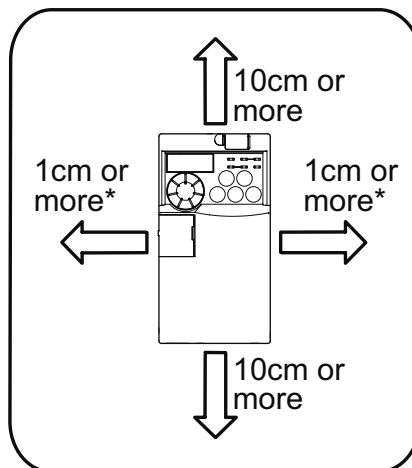

* When using the inverters at the surrounding air temperature of 40°C or less, the inverters can be installed without any clearance between them (0cm clearance).

When surrounding air temperature exceeds 40°C , clearances between the inverters should be 1cm or more (5cm or more for the 5.5K or more).

Clearances (side)

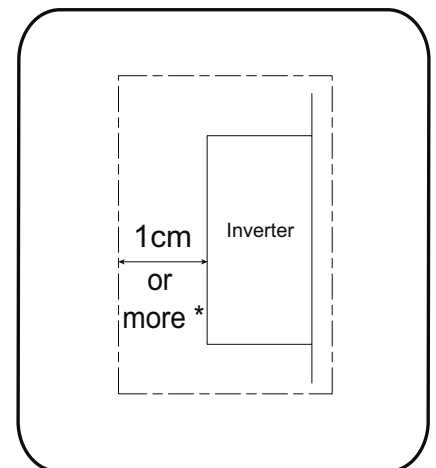

* 5cm or more for the 5.5K (SC) or more

Above inverter

Heat is blown up from inside the inverter by the small fan built in the unit. Any equipment placed above the inverter should be heat resistant.

Arrangement of multiple inverters

When multiple inverters are placed in the same enclosure, generally arrange them horizontally as shown below in the figure (a). When it is inevitable to arrange them vertically to minimize space, take such measures as to provide guides since heat from the bottom inverters can increase the temperatures in the top inverters, causing inverter failures. When mounting multiple inverters, fully take caution not to make the surrounding air temperature of the inverter higher than the permissible value by providing ventilation and increasing the panel size.

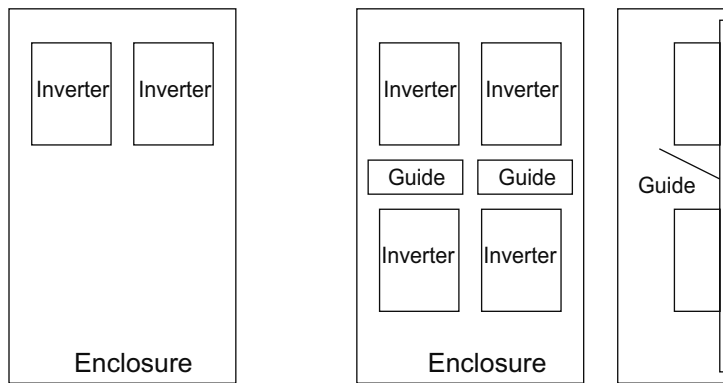

(a) Arranged horizontally (b) Arranged vertically

Arrangement of multiple inverters

Arrangement of ventilation fan and inverter

Heat generated in the inverter is blown up from the bottom of the unit as warm air by the cooling fan. When installing a ventilation fan for that heat, determine the place of ventilation fan installation after fully considering an air flow. (Air passes through areas of low resistance. Make an airway and airflow plates to expose the inverter to cool air.)

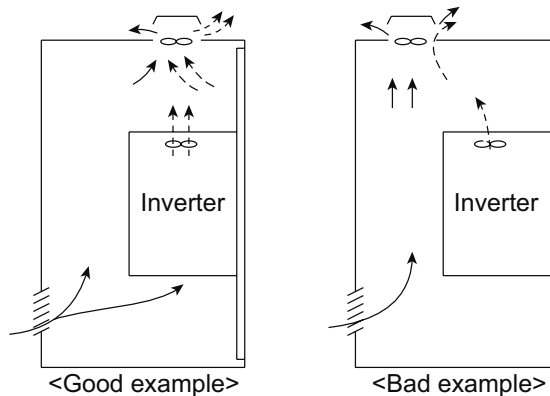

Arrangement of the ventilation fan and inverter

2.4.2 Troubleshooting

When a fault occurs in the inverter, the inverter trips and the PU display automatically changes to one of the following fault or alarm indications.

◎ Retention of fault output signal

When the magnetic contactor (MC) provided on the input side of the inverter is opened when a fault occurs, the inverter's control power will be lost and the fault output will not be held.

◎ Fault or alarm indication

When a fault or alarm occurs, the operation panel display automatically switches to the fault or alarm indication.

◎ Resetting method

When a fault occurs, the inverter output is kept stopped. Unless reset, therefore, the inverter cannot restart.

When any fault occurs, take the appropriate corrective action, then reset the inverter, and resume operation. Not doing so may lead to the inverter fault and damage.

Inverter fault or alarm indications are roughly categorized as below.

1 Error message

A message regarding operational fault and setting fault by the operation panel and parameter unit (FR-PU04 /FR-PU07) is displayed. The inverter does not trip.

2 Warning

The inverter does not trip even when a warning is displayed. However, failure to take appropriate measures will lead to a major fault.

3 Minor failure

The inverter does not trip. You can also output a minor failure signal by making parameter setting.

4 Major fault

When a fault occurs, the inverter trips and a fault signal is output.

<Reference>

Refer to Appendix 2 as it contains a list of fault displays and the appropriate troubleshooting steps to resolve the issue.

MEMO

Inverter basics

Chapter 3

Parameters

Inverter basics

You must have an understanding of parameters in order to configure "inverters". We will use the belt conveyor example described in Chapter 1 again here. If the motor moving the belt conveyor is not rotated smoothly, items on the belt conveyor could fall off and break. The motor must be started slowly to ensure that the conveyor moves smoothly.

The motor can be rotated smoothly in such a manner by configuring inverter parameters. This chapter will introduce typically used parameters.

3.1 Setting basic parameters

3.1.1 Brief description of parameters

Parameters are the values used to configure inverter operation. These are notated as "Pr.". The type and number of parameters available differ depending on inverter model.

For simple variable-speed operation of the inverter, the initial values of the parameters may be used as they are. Configure the necessary parameters in accordance with loads and operational specifications. Parameters can be configured, changed, and confirmed from the operation panel.

3.1.2 Typical parameters

The following table lists the most commonly used parameters.

Pr.	Name	Unit	Initial value	Range	Application
0	Torque boost	0.1%	6%/4%/3%/2%*	0 to 30%	Set when you want to increase a starting torque or when the motor with a load will not rotate, resulting in an alarm [OL] and a trip [OC1]. * Initial values differ according to the inverter capacity. (0.75K or lower/1.5K to 3.7K/5.5K, 7.5K/11K, 15K)
1	Upper-limit frequency	0.01Hz	120Hz	0 to 120Hz	Configure this to set a limit on the maximum output frequency.
2	Lower-limit frequency	0.01Hz	0Hz	0 to 120Hz	Configure this to set a limit on the minimum output frequency.
3	Base frequency	0.01Hz	60Hz	0 to 400Hz	Configure this when the rate frequency of the motor is not 60Hz. Check the motor rating plate.
4	Multi-speed setting (high speed)	0.01Hz	60Hz	0 to 400Hz	Configure this to change the preset speed parameter with a terminal.
5	Multi-speed setting (middle speed)	0.01Hz	30Hz	0 to 400Hz	
6	Multi-speed setting (low speed)	0.01Hz	10Hz	0 to 400Hz	
7	Acceleration time	0.1 s	5s/10s/15s*	0 to 3600 s	Acceleration/deceleration time can be set. * Initial values differ according to the inverter capacity.
8	Deceleration time	0.1 s	5s/10s/15s*	0 to 3600 s	
9	Electronic thermal O/L relay	0.01A	Inverter rated current	0 to 500A	(3.7K or lower/5.5K, 7.5K/11K, 15K)
79	Operation mode selection	1	0	0	External/PU switchover mode
				1	Fixed to PU operation mode
				2	Fixed to External operation mode
				3	External/PU operation mode 1 (Start command from External, frequency command from PU)
				4	External/PU operation mode 2 (Frequency command from External, start command from PU)
				6	Switchover mode
				7	External operation mode (PU operation interlock)
Pr.CL	Parameter clear	1	0	0, 1	Setting "1" returns all parameters except calibration parameters to the initial values.
ALLC	All parameter clear	1	0	0, 1	Setting "1" returns all parameters to the initial values.

POINT

- Parameters are configured with initial values so that inverters can operate without specific configuration. Parameters can be configured in accordance with the motors and devices used in your environment.

3.2 Operation panel

3.2.1 Names and functions of the operation panel

The operation panel cannot be removed from the inverter.

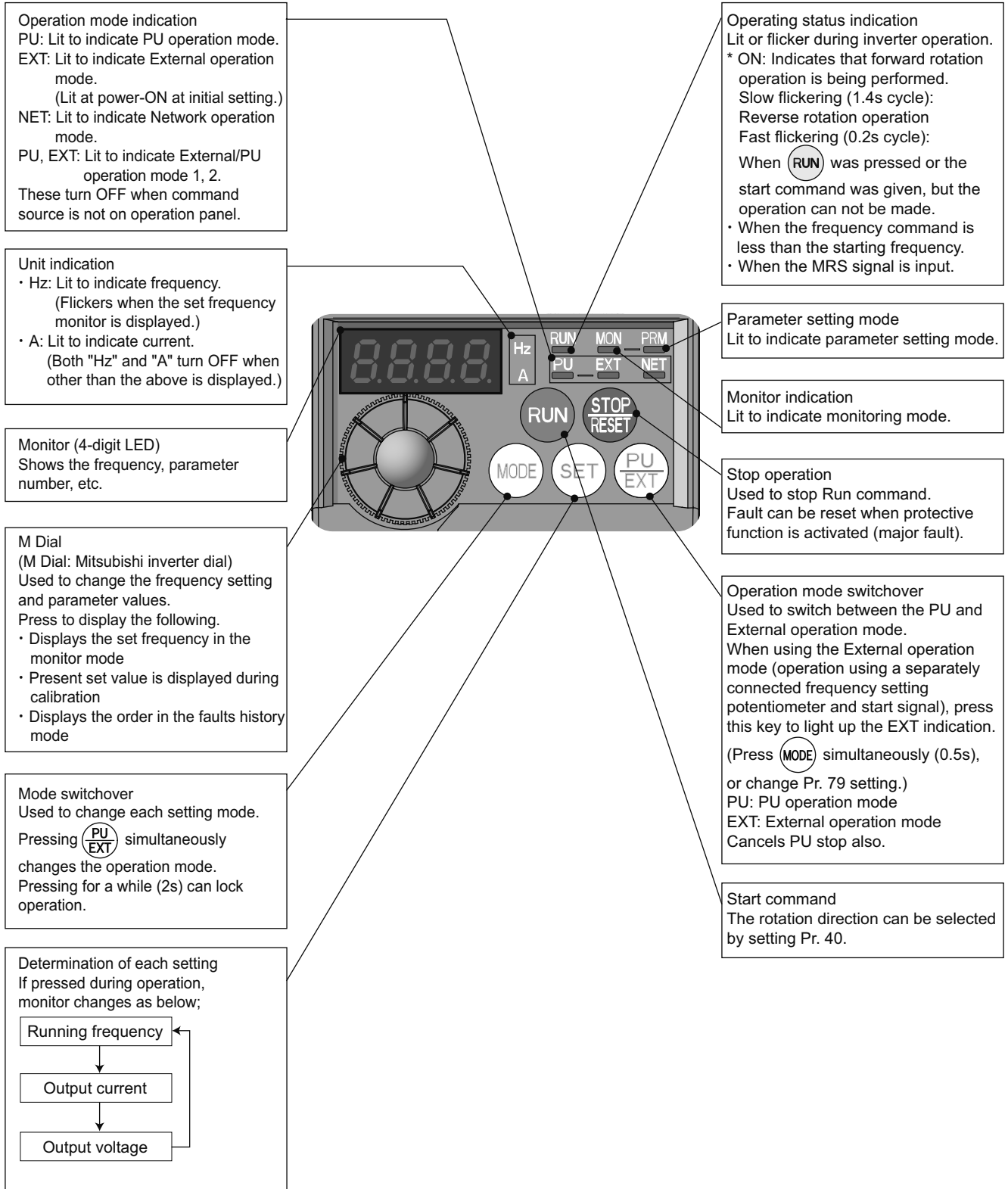

3.3 Selecting the operation mode and command source

3.3.1 Various operation modes

One of the key features of the inverter is the capability to be controlled with various signals. The operation mode specifies the source of start commands and frequency commands.

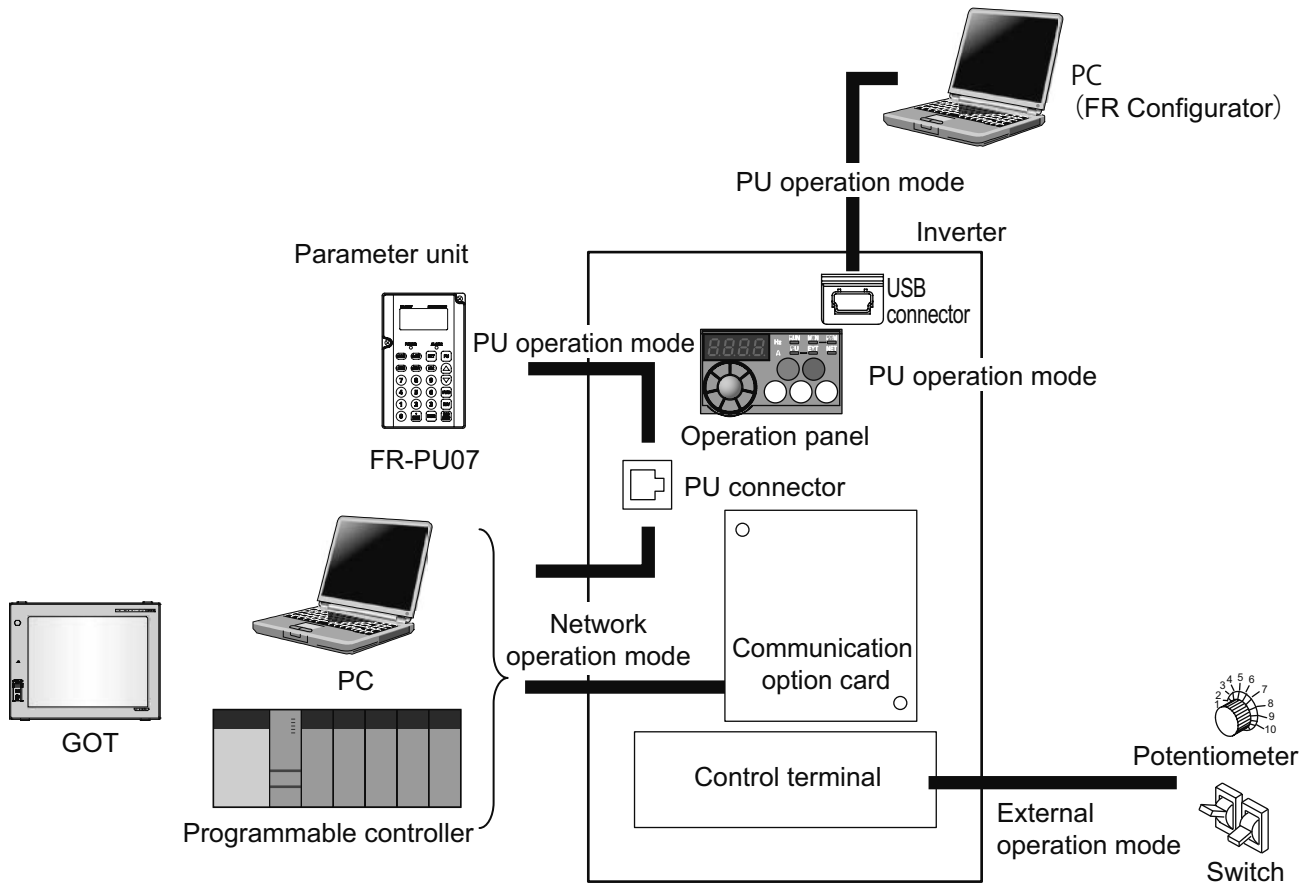















POINT

- Mitsubishi Electric factory automation devices such as programmable controllers and GOTs are equipped with Mitsubishi general-purpose inverter protocols for easy integration by simply connecting cables and configuring communication settings.

3.3.2 Operation mode selection (Pr. 79)

Used to select the operation mode of the inverter. Mode can be changed as desired among operation using external command signals (External operation), operation from the operation panel and PU (FR-PU07/FR-PU04) (PU operation), combined operation of PU operation and External operation (External/PU combined operation), and Network operation (when RS-485 communication or a communication option is used).

Pr.	Name	Initial value	Setting range	Description	LED Indication		
79	Operation mode selection	0	0	Use External/PU switchover mode ($\frac{PU}{EXT}$) to switch between the PU and External operation mode. At power on, the inverter is in the External operation mode.	External operation mode  PU operation mode 		
			1	Fixed to PU operation mode			
			2	Fixed to External operation mode Operation can be performed by switching between the External and NET operation mode.	External operation mode  NET operation mode 		
			3	External/PU operation mode 1		Operation panel and PU (FRPU04/FR-PU07) setting or external signal input (multi-speed setting, across terminals 4-5 (valid when AU signal turns ON)).*	External signal input (terminal STF, STR) 
				Frequency command	Start command		
			4	External/PU operation mode 2		External signal input (terminal 2, 4, JOG, multi-speed selection, etc.)	Enter from  of the operation panel and  and  of the PU (FR-PU04/FR-PU07)
				Frequency command	Start command		
			6	Switchover mode Switchover between PU operation, External operation, and NET operation is available while keeping the same operation status.	PU operation mode  External operation mode  NET operation mode 		
			7	External operation mode (PU operation interlock) X12 signal ON Operation mode can be switched to the PU operation mode. (output stop during external operation) X12 signal OFF Operation mode can not be switched to the PU operation mode.	PU operation mode  External operation mode 		

* The priority of frequency commands when Pr. 79="3" is: Multi-speed operation (RL/RM/RH/REX) > PID control (X14) > terminal 4 analog input (AU) > Digital input from the operation panel.

3.4 Basic operation modes

3.4.1 External operation mode

External operation mode is used to input start and frequency commands with external potentiometers and switches connected to the control circuit terminal.

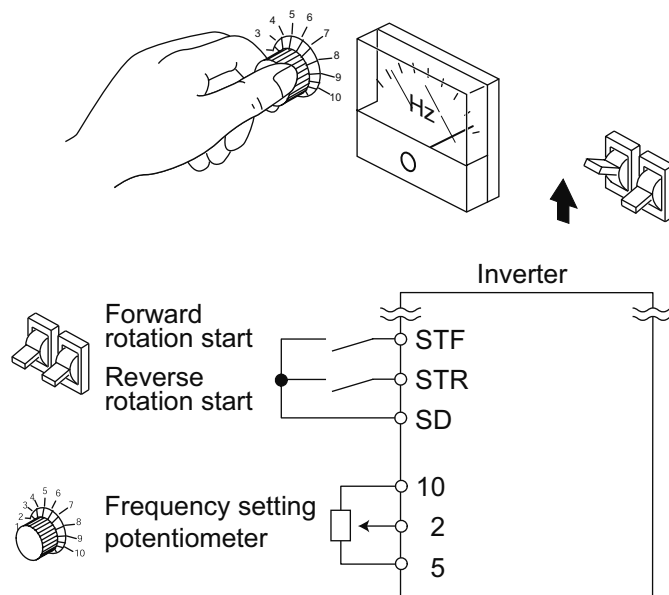

3.4.2 PU operation mode

PU operation mode is used to input start and frequency commands with operation panels or parameter units (FR-PU04/FR-PU07).

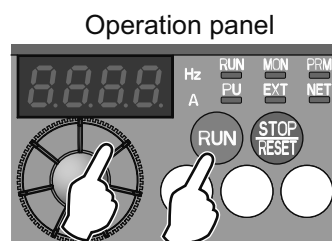
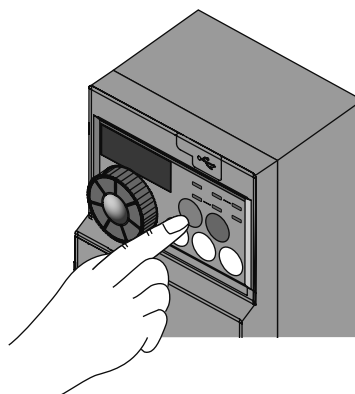

3.4.3 External/PU operation mode 1

Select the External/PU operation mode 1 when applying frequency command from the operation panel or parameter unit (FR-PU04/FRPU07) and inputting the start command with the external start switch.

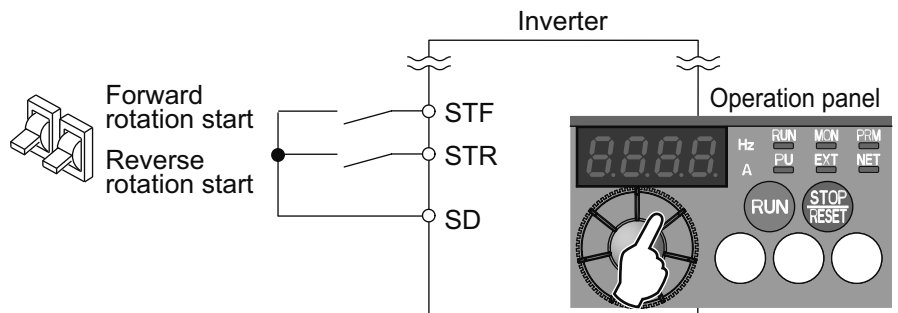
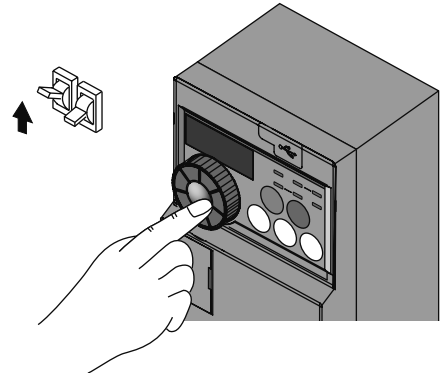

3.4.4 External/PU operation mode 2

Select the External/PU operation mode 2 to input frequency commands from an external potentiometer or multi-speed and JOG signals, or to input start commands via key operation of the operation panel or parameter unit (FR-PU04/FR-PU07).

- Select "4" for Pr. 79. You cannot change to the other operation mode.

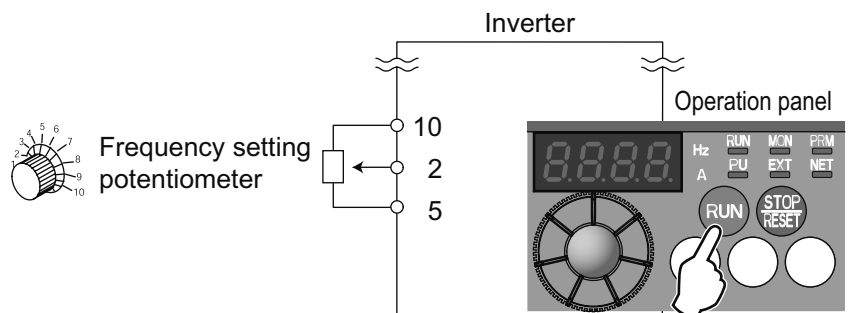
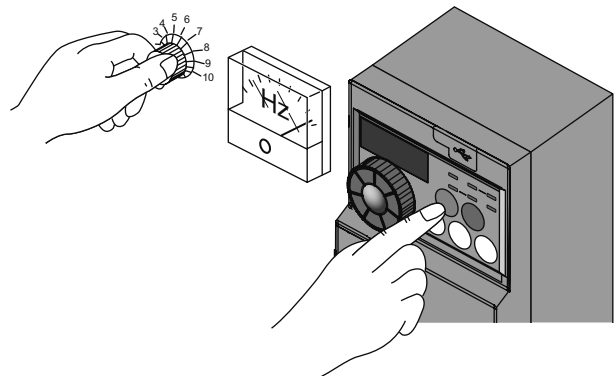

3.5 How to configure parameters

3.5.1 Parameter clear/All parameter clear

Parameter settings may have been changed if the inverter is used.
Use this procedure to restore parameters to their initial values.

	Operation		Display
1	Screen at power-ON The monitor display appears.		
2	Changing the operation mode Press to choose the PU operation mode.	→	PU indication is lit.
3	Parameter setting mode Press to choose the parameter setting mode.	→	PRM indication is lit. (The parameter number read previously appears.)
4	Selecting the parameter number Turn until <i>Pr.CL (ALLC)</i> appears	→	Parameter clear All parameter clear
5	Reading settings Press to read the present setting. "0"(initial value) appears.	→	
6	Changing the setting Turn to change it to the set value "1".	→	
7	Parameter settings Press to finalize the setting. "1" and "Pr.CL"/"ALLC" flashes.	→	 Parameter clear All parameter clear

Setting	Description
0	Not executed.
1	Set parameters back to the initial values. (Parameter clear sets back all parameters except calibration parameters, terminal function selection parameters to the initial values.) Refer to the parameter list for information on the availability of clear parameter and clear all parameters functions for each parameter.

POINT

- Check the values of several parameter settings when the clear all parameters function cannot be performed.
Pr. 77 "0", Pr. 79 "0", Pr. 340 "10", and Pr. 551 "9999"

3.5.2 Pr. 9 Electronic thermal O/L relay







Configure the current value for the electronic thermal O/L relay to enable motor overheating protection. This can help you achieve optimal protection capability for various operating conditions such as low-speed operation and reduced motor cooling capacity.

Pr.	Name	Initial value	Setting range	Description
9	Electronic thermal O/L relay	Inverter rated current *1	0 to 500A	Set the rated motor current.

*1 The inverter rated current is configured to 85% for values of 0.75K or less.

This function detects the motor overload (overheating) and trips the inverter by stopping the operation of the transistor at the inverter output side.

- Set the rated current value (A) of the motor in Pr. 9.
(If the motor has both 50Hz and 60Hz rating and the Pr. 3 Base frequency is set to 60Hz, set the 1.1 times of the 60Hz rated motor current.)
- Set "0" in Pr. 9 when you do not want to operate the electronic thermal O/L relay, e.g. when using an external thermal relay with the motor. (Note that the output transistor protection of the inverter functions (E.THT).)

Operation example	
1	Screen at power-ON The monitor display appears.
2	Changing the operation mode Press  to choose the PU operation mode. The [PU] indicator turns on.
3	Parameter setting mode Press  to choose the parameter setting mode.
4	Selecting the parameter number Turn  until  (Pr. 9) is selected.
5	Reading settings Press  to read the present setting. " 0.68" (0.68A (initial value)) appears.
6	Changing the setting Turn  to change the setting to " 0.63" (0.63A).
7	Parameter settings Press  to finalize the setting. The parameter number and setting flashes.







* Configure parameter settings in accordance with your environment.

3.5.3 Pr. 3 Base frequency

Use this function to adjust the inverter output (voltage, frequency) to match the motor rating.

Pr.	Name	Initial value	Setting range	Description
3	Base frequency	60Hz	0 to 400Hz	Rated motor frequency. (50Hz/60Hz)

- When operating a standard motor, generally set the rated frequency of the motor to Pr. 3 Base frequency. When running the motor using commercial power supply-inverter switch-over operation, set Pr. 3 to the same value as the power supply frequency.
- If the frequency given on the motor rating plate is "50Hz" only, always set to "50Hz". Leaving the base frequency unchanged from "60Hz" may make the voltage too low and the torque insufficient. It may result in an inverter trip due to overload.

Operation example	
1	Screen at power-ON The monitor display appears.
2	Changing the operation mode Press  to choose the PU operation mode. The [PU] indicator turns on.
3	Parameter setting mode Press  to choose the parameter setting mode.
4	Selecting the parameter number Turn  until $P. \quad 3$ (Pr. 3) is selected.
5	Reading settings Press  to read the present setting. "60.00" (60.00Hz (initial value)) appears.
6	Changing the setting Turn  to change the setting to "50.00" (50.00Hz).
7	Parameter settings Press  to finalize the setting. The parameter number and setting flashes.

* Configure parameter settings in accordance with your environment.

3.5.4 Pr. 0 Torque boost

This parameter is used to correct voltage drops in low-frequency ranges and improve decreases in motor torque during low speeds.

- Motor torque during low-frequency ranges can be adjusted in accordance with load and can be increased during startup.

Pr.	Name	Initial value		Setting range	Description
0	Torque boost	0.1K to 0.75K	6%	0 to 30%	Set the output voltage at 0Hz as %.
		1.5K to 3.7K	4%		
		5.5K, 7.5K	3%		
		11K, 15K	2%		

1. Starting torque adjustment

- On the assumption that Pr. 19 Base frequency voltage is 100%, set the output voltage at 0Hz in % to Pr. 0.
- Adjust the parameter little by little (about 0.5%), and check the motor status each time. If the setting is too large, the motor will overheat. The guideline is about 10% at the greatest.

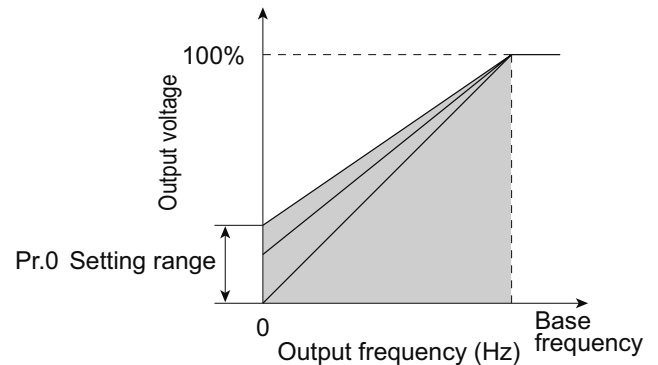

Operation example	
1	Screen at power-ON The monitor display appears.
2	Changing the operation mode Press to choose the PU operation mode. The [PU] indicator turns on.
3	Parameter setting mode Press to choose the parameter setting mode.
4	Selecting the parameter number Turn until (Pr. 0) is selected.
5	Reading settings Press to read the present setting. " " (6.0% (initial value)) appears.
6	Changing the setting Turn to change the setting to " " (3.0%).
7	Parameter settings Press to finalize the setting. The parameter number and setting flashes.

* Configure parameter settings in accordance with your environment.

3.5.5 Pr. 1, 2 Upper-limit/lower-limit frequency

These parameters can be used to restrict motor speed.

These parameters are used to set upper and lower limits on output frequency.

Pr.	Name	Initial value	Setting range	Description
1	Upper-limit frequency	120Hz	0 to 120Hz	Upper limit of the output frequency
2	Lower-limit frequency	0Hz	0 to 120Hz	Lower limit of the output frequency

(1) Set upper-limit frequency

- Use Pr. 1 Upper-limit frequency to set the maximum frequency. If the frequency of the frequency command entered is higher than the setting, the output frequency is clamped at the upper-limit frequency.

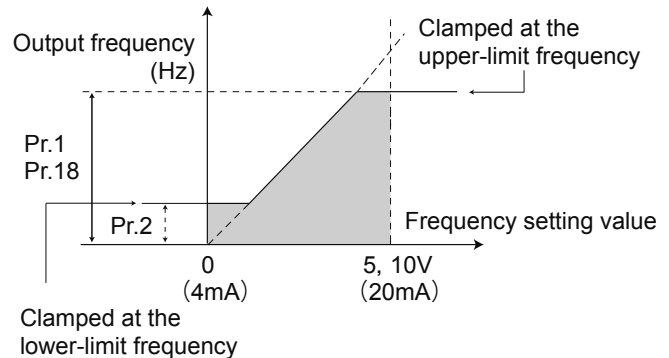

(2) Set lower-limit frequency

- Use Pr. 2 Lower-limit frequency to set the minimum frequency.
- If the set frequency is less than Pr. 2, the output frequency is clamped at Pr. 2 (will not fall below Pr. 2).

Operation example	
1	Screen at power-ON The monitor display appears.
2	Changing the operation mode Press to choose the PU operation mode. The [PU] indicator turns on.
3	Parameter setting mode Press to choose the parameter setting mode.
4	Selecting the parameter number Turn until Pr. 1 is selected.
5	Reading settings Press to read the present setting. "120.0" (120.0Hz (initial value)) appears.
6	Changing the setting Turn to change the setting to "60.00" (60.00Hz).
7	Parameter settings Press to finalize the setting. The parameter number and setting flashes.

* Configure parameter settings in accordance with your environment.

3.5.6 Pr. 7, 8 Acceleration/deceleration time

These parameters are used to configure the motor acceleration/deceleration time.

Set larger values for slower acceleration/deceleration and smaller values for faster acceleration/deceleration.

Pr.	Name	Initial value		Setting range	Description
7	Acceleration time	3.7K or less	5s	0 to 3600/360s	Motor acceleration time
		5.5K, 7.5K	10s		
		11K, 15K	15s		
8	Deceleration time	3.7K or less	5s	0 to 3600/360s	Motor deceleration time
		5.5K, 7.5K	10s		
		11K, 15K	15s		
20	Acceleration/ deceleration reference frequency	60Hz		1 to 400Hz	Frequency that will be the basis of acceleration/deceleration time As acceleration/deceleration time, set the frequency change time from stop to Pr. 20.

(1) Acceleration time setting (Pr. 7, Pr. 20)

- Pr. 7 acceleration time configures the acceleration time required to reach the Pr. 20 acceleration/deceleration reference frequency from a stopped state.

(2) Deceleration time setting (Pr. 8, Pr. 20)

- Pr. 8 acceleration time configures the deceleration time required to stop from the Pr. 20 acceleration/deceleration reference frequency.

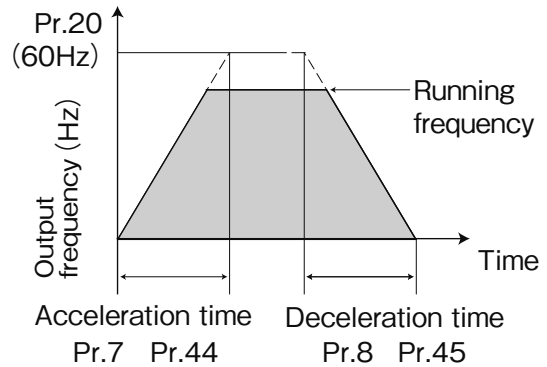

Operation example	
1	Screen at power-ON The monitor display appears.
2	Changing the operation mode Press to choose the PU operation mode. The [PU] indicator turns on.
3	Parameter setting mode Press to choose the parameter setting mode.
4	Selecting the parameter number Turn until (Pr. 7) is selected.
5	Reading settings Press to read the present setting. " 5.0" (5.0 seconds (initial value)) appears.
6	Changing the setting Turn to change the setting to " 10.0" (10.0 seconds).
7	Parameter settings Press to finalize the setting. The parameter number and setting flashes.

* Configure parameter settings in accordance with your environment.

MEMO

Chapter 4

How to use FR Configurator

Using FR Configurator makes parameter configuration even easier.

Many parameters can be configured in single batch operations with the software "FR Configurator".

This chapter will cover how to connect the inverter to a PC, Easy Setup, and finally basic operation of the software.

Using this software also enables you to save configuration data for devices.

You can easily take configurations created for testing and prototype environments and copy them to mass-production equipment and devices.

4.1 Fundamental knowledge to operate FR Configurator

4.1.1 Items needed for connectivity

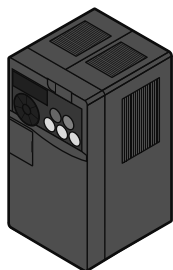

Inverter



PC (FR Configurator)



USB cable

4.1.2 Connection method

All you need to connect a PC and inverter is a single USB cable. Only peer-to-peer connections can be established. USB hubs cannot be used to make connections.

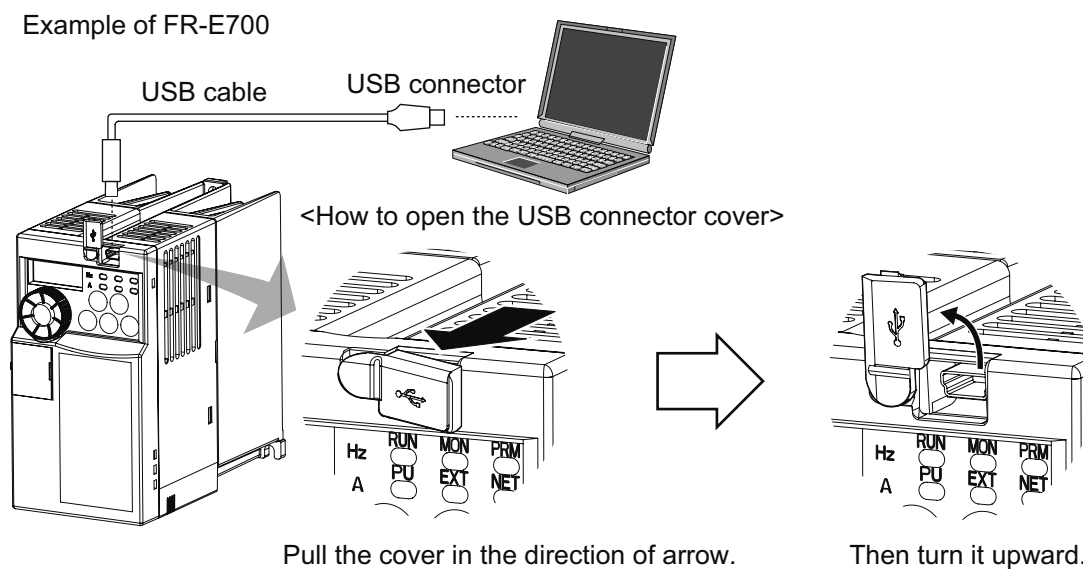

4.1.3 Startup

The "Startup" window is displayed when FR Configurator is started. Each function can be directly selected from the "Startup" window.

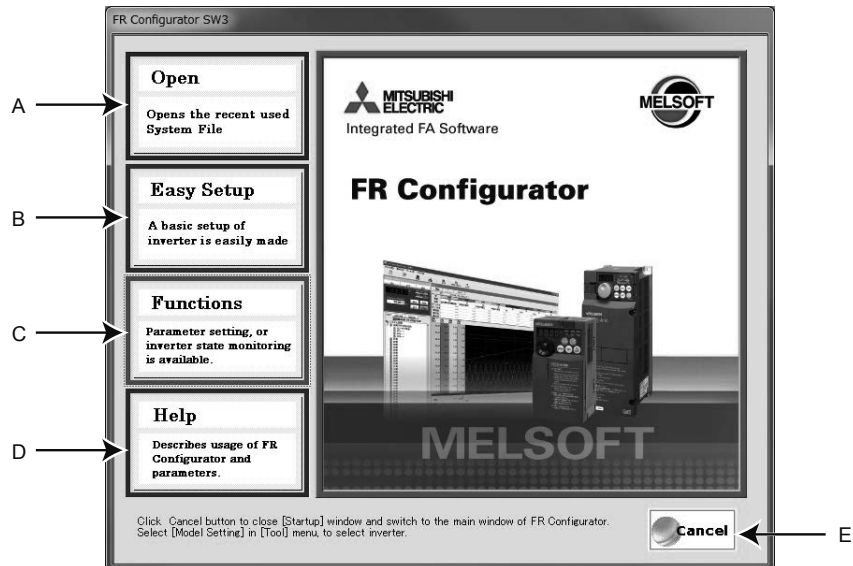

No.	Name	Function and description
A	Open	Shows up to five recent used files. Point a cursor on "Open", and five recent used files are shown. Click the file name, then "Startup" window is closed, and Main frame is displayed with the file contents reflected.
B	Easy Setup	Click to start Easy Setup. From System Property setting to Model setting and parameter setting, the system setting up is easily made with wizard style (interactive manner).
C	Functions	Shows a list of functions.
D	Help	Displays Help window.
E	Cancel	Click to close this window, and returns to Main frame.

4.1.4 Screen configuration (Main frame)

The Main frame (main window) of FR Configurator consists of three areas.

- Navigation area

An area for showing information of the registered inverter, or for making settings. "Test Operation", "System Settings", "Setting Wizard", and "Troubleshooting" are available in this area.

- Monitor area

An area for showing obtained monitor data of the inverter. "Graph", "I/O Terminal Monitor", "Machine Analyzer", "Batch Monitor" are available in this area.

- System area

An area for showing and read/write parameters, or for converting from parameter setting of conventional model. "Parameter List", "Diagnosis" and "Convert" are available in this area.

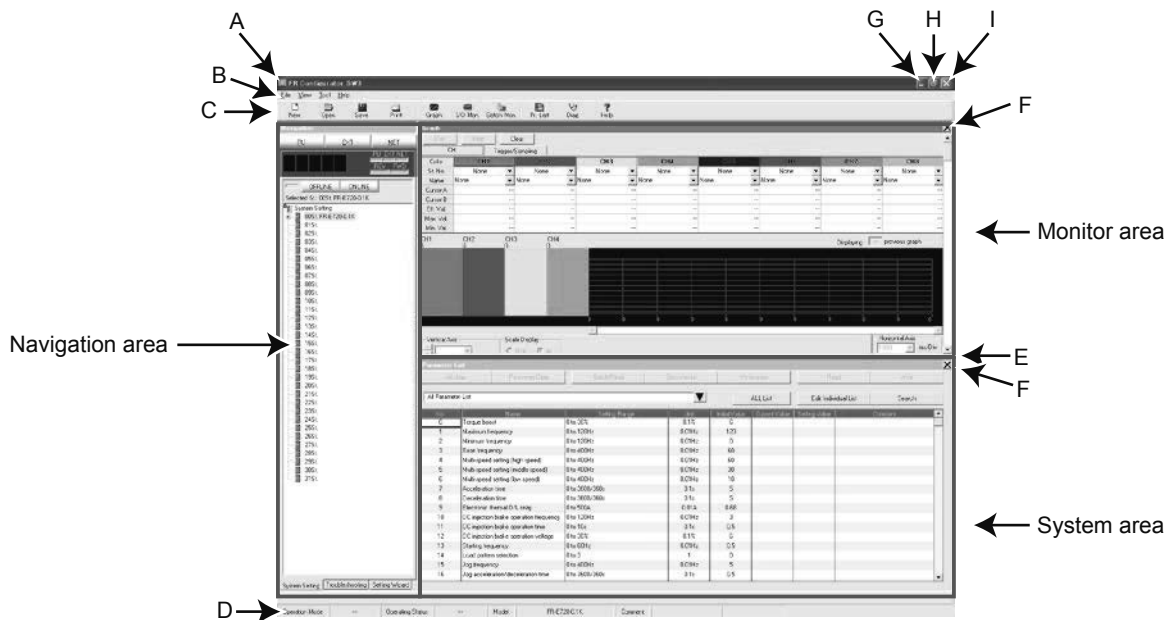

No.	Name	Function and description
A	Title bar	"FR Configurator SW3" is displayed on the title bar. If a system file has been read, or has been saved, the file name is displayed.
B	Menu bar	Each function is available by selecting from the menu.
C	Tool bar	Each function is available by clicking icons of the tool bar.
D	Status bar	The model name, Operating status, etc. are shown.
E	Split line	Adjustment of System area size and Monitor area size is available.
F	Conceal button	Conceals the Monitor area and System area.
G	Minimize button	Minimizes the Main frame window size of FR Configurator.
H	Maximize button	Maximizes the Main frame window size of FR Configurator.
I	Close button	Closes FR Configurator.

4.1.5 Screen configuration (Navigation area)

The Navigation area is for showing registered inverter information, switching of operation mode and ONLINE/OFFLINE, sending of start/stop command, changing of the set frequency, or starting Setting Wizard. "Test Operation", "System Settings", "Troubleshooting" and "Setting Wizard" are available in this area.

The Upper part of the Navigation area displays "Test Operation", and the lower part displays "System View". Select [System Setting], [Troubleshooting] or [Setting Wizard] under [View] menu to switch the function displayed in "System View".

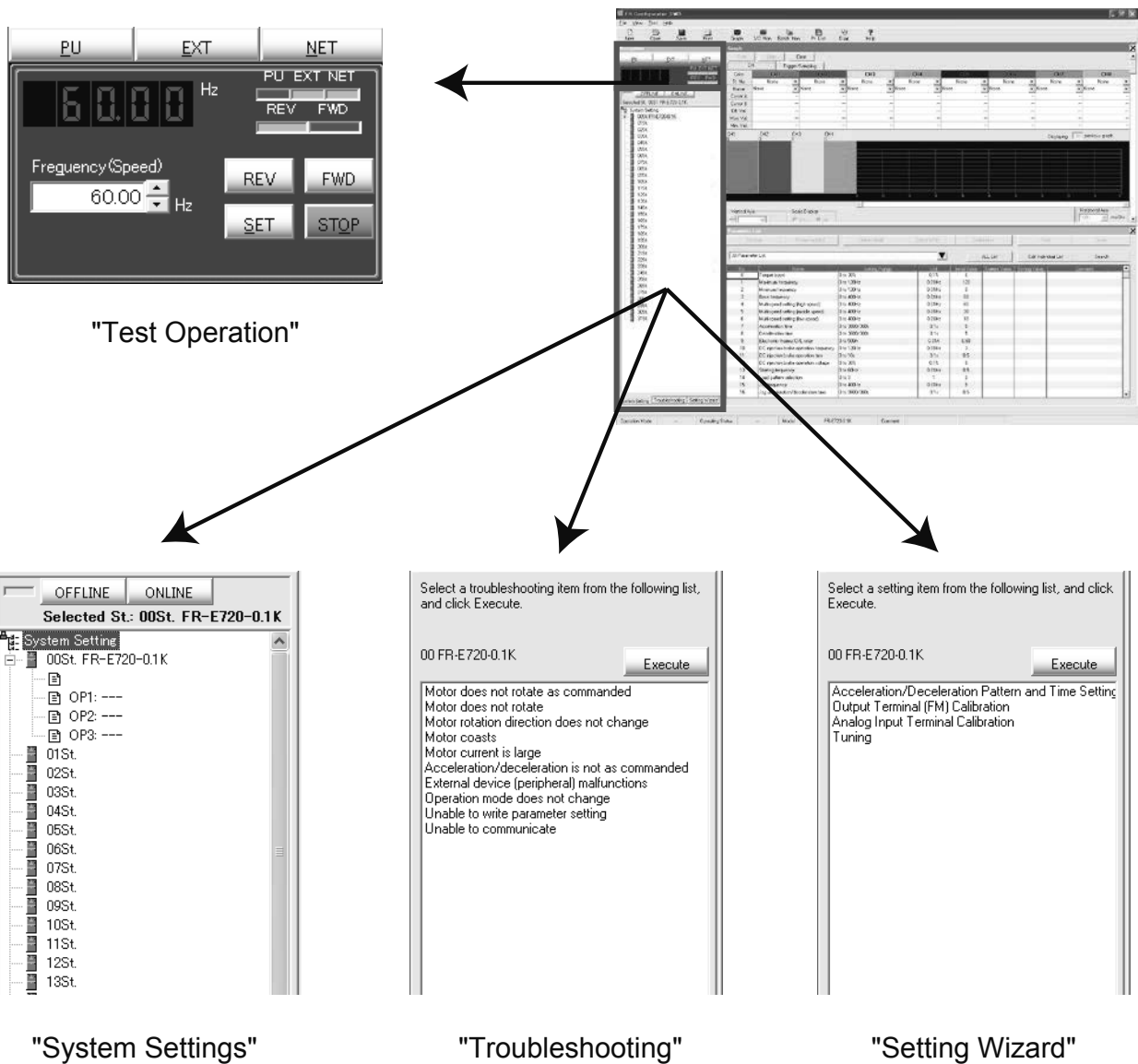

4.1.6 Screen configuration (System area)

The System area is for showing and reading/writing parameters, or for diagnosis and converting from parameter setting of conventional model. "Parameter List", "Diagnosis", and "Convert" are available in this area.

Select [Parameter List], [Diagnosis], or [Convert] under [View] menu, or click icons on the tool bar to switch the function displayed in the System area.

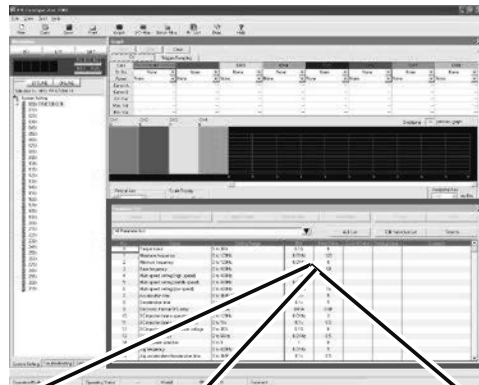

"Parameter List"



"Diagnosis"



"Convert"

4.1.7 Screen configuration (Monitor area)

Monitor area is for showing obtained monitor data of inverter. "Graph", "I/O Terminal Monitor", "Machine Analyzer", and "Batch Monitor" are available in this area.

Select [Graph], [Machine Analyzer], [Batch Monitor], or [I/O Terminal Monitor] under [View] menu, or click an icon on the tool bar to display the function in Monitor area.

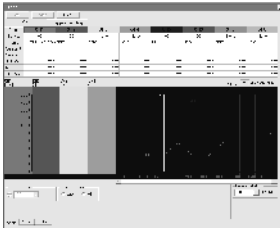

"Graph"

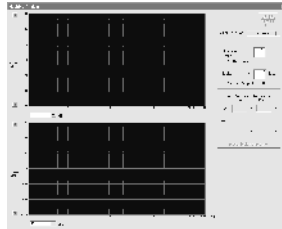

"Machine Analyzer"

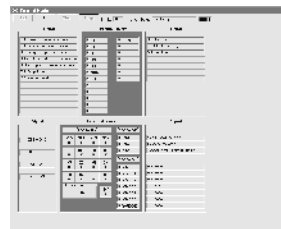

"I/O Terminal Monitor"

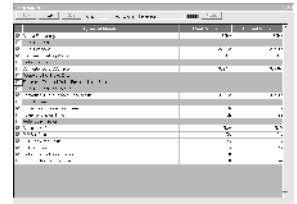

"Batch Monitor"

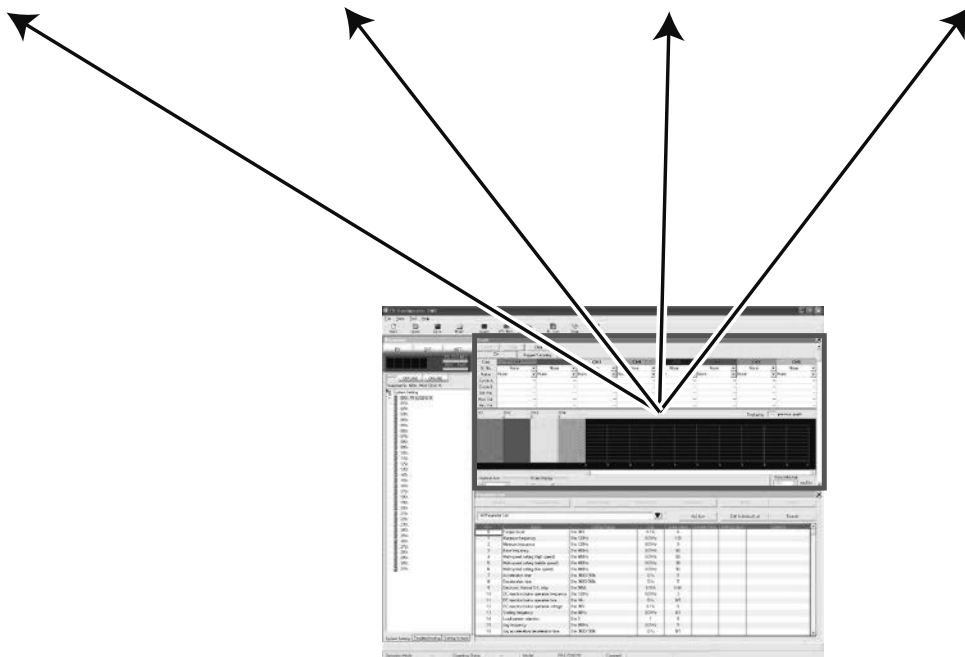

4.2 Easy Setup

4.2.1 Configuration method

Setting from system setting to parameter setting is easily performed with Easy Setup. Even without FR Configurator knowledge, without regard to the parameter number, system setting and basic parameter setting is easily performed.

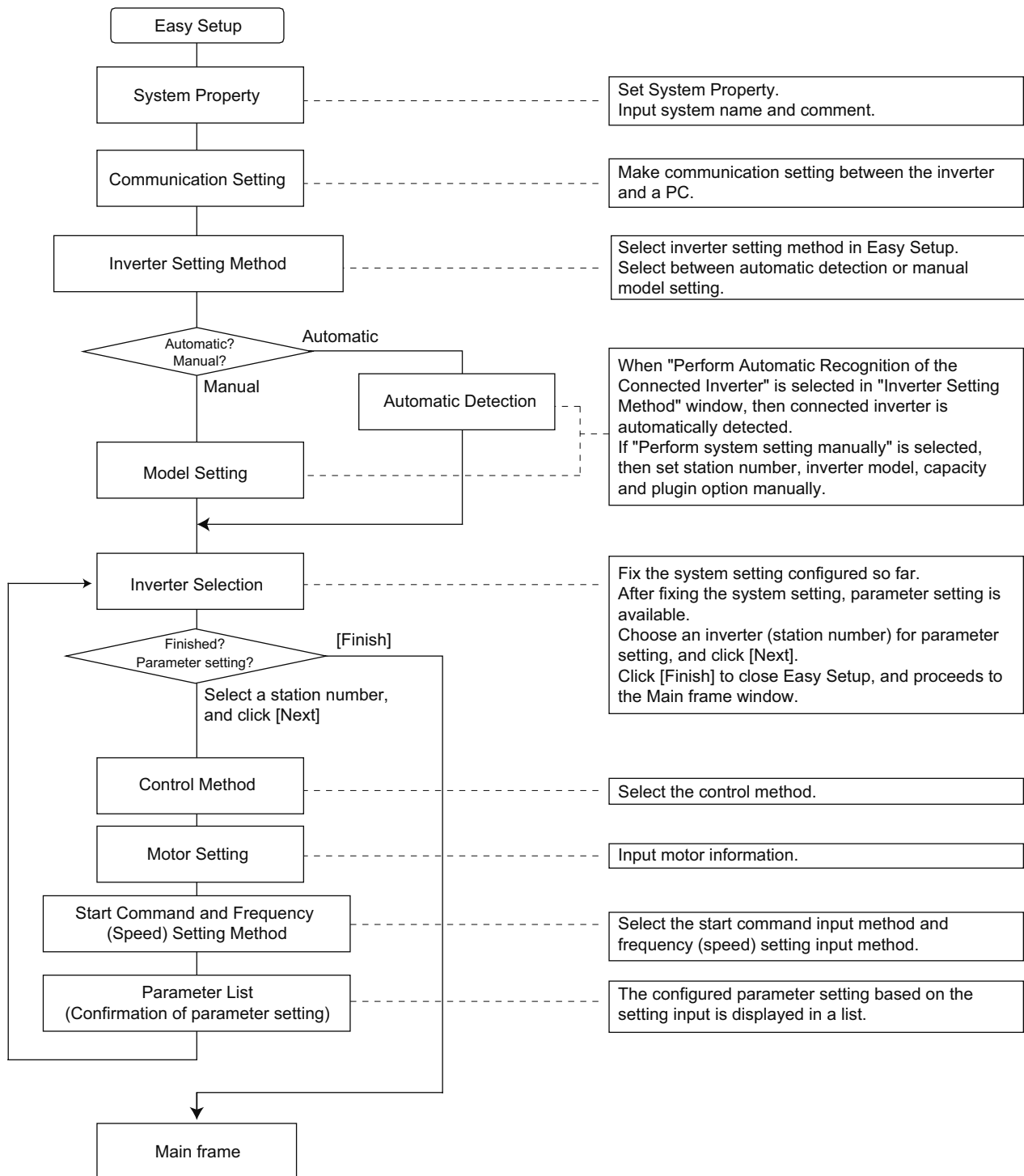

4.2.2 System property

Input an information for creating a system file.

Type a system name (up to 32 one byte characters) for this system file. Click [Next] after inputting the system name. When [Next] is clicked, the screen proceeds to "Communication Setting".

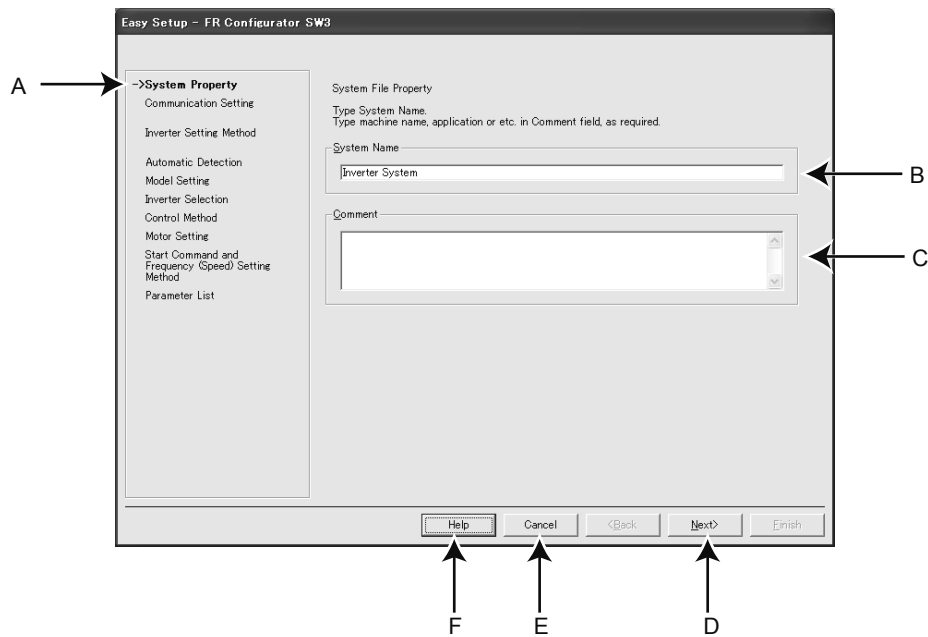

No.	Name	Function and description
A	System Property	Shows description of current setting and next/previous setting in Easy Setup.
B	System Name	Type a system name up to 32 one byte characters.
C	Comment	A field for comments (up to 256 one byte characters) to describe the system.
D	Next>	Proceeds to "Communication Setting".
E	Cancel	Disables the settings and closes Easy Setup.
F	Help	Displays Help window.

4.2.3 Communication setting

Adjust the communication setting between a PC and the inverter.

When communicating with the inverter using a USB port of the PC, select "USB" in "PC side Port" field,

Click [Next].

When communicating with the inverter using a serial port of the PC, select "RS-232C" in "PC side Port" field.

POINT

- The communication setting is used for an initial value of inverter.
- Check the PC-side port (serial/USB) and PC port number (1 to 63).

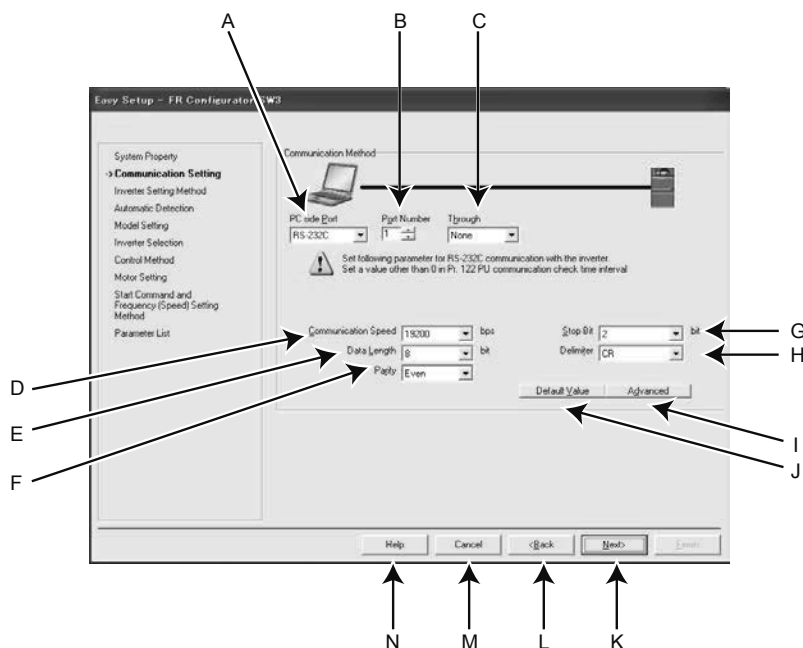

No.	Name	Initial value	Function and description
A	PC side Port	RS-232C	Select the communication port from RS-232C or USB. (USB communication is only available with FR-A700, A701, B, B3, E700EX and E700(SC)(NC) series.)
B	Port Number	1	Select the PC communication port number.
C	Through	None	Select when connecting through GOT.
D	Communication Speed	19200	Set the communication speed.
E	Data Length	8	Set the data bit length.
F	Parity	Even	Specify the parity bit
G	Stop Bit	2	Set the stop bit length.
H	Delimiter	CR	Specify the delimiter of the data end.
I	Advanced		Displays "Advanced" window. Setting of timeout and number of retry is available.
J	Default Value		Restores the initial communication setting of the inverter.
K	Next>		Proceeds to "Inverter Setting Method".
L	<Back		Returns to "System Setting".
M	Cancel		Disables the settings and closes Easy Setup.
N	Help		Displays Help window.

4.2.4 Inverter setting method

Select inverter setting method between automatic recognition of the connected inverter, or manually model setting for this system.

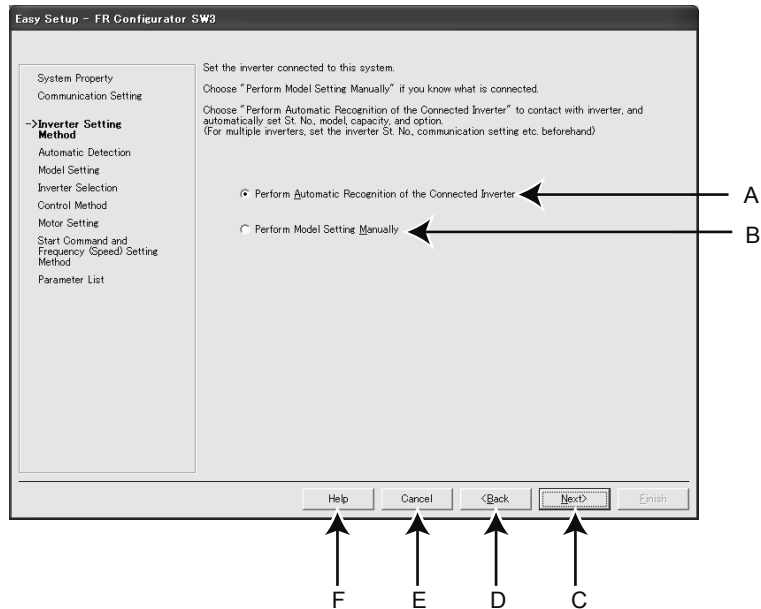

No.	Name	Function and description
A	Perform <u>A</u> utomatic Recognition of the Connected Inverter	Choose "Perform <u>A</u> utomatic Recognition of the Connected Inverter" and click to [Next] automatically detect the connected inverter. After finishing the automatic detection of the inverter, the window proceeds to "Inverter Selection".
B	Perform Model Setting <u>M</u> anually	Make the model setting manually.
C	<u>N</u> ext>	When "Perform <u>A</u> utomatic Recognition of the Connected Inverter" is selected, the window proceeds to "Automatic Detection". If "Perform Model Setting <u>M</u> anually" is selected, the window proceeds to "Model Setting".
D	< <u>B</u> ack	Returns to "Communication Setting".
E	Cancel	Closes Easy Setup with the invalid setting.
F	Help	Displays Help window.

4.2.5 Automatic detection

Click [Next] to detect inverter of which communication is available.

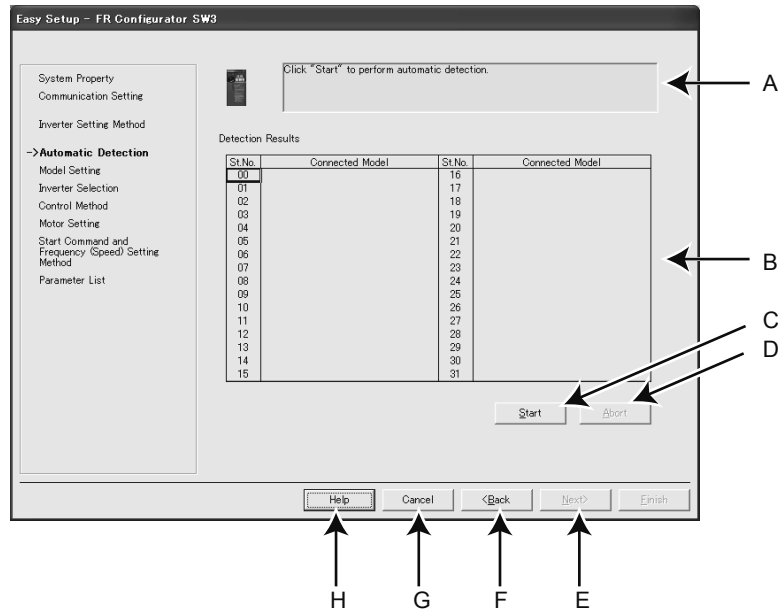

No.	Name	Function and description
A	Message area	Shows a state of automatic detection. When an inverter is detected, the color turns blue, and shows a result of detection. (If an error occurred during automatic detection, the color turns red, and shows error description.)
B	Detection Results	Shows a result of automatic detection. A station during detecting is displayed in blue. And when an inverter is detected, inverter model name is displayed. (For a station failed for detection, the color turns red, and shows error code.)
C	<u>S</u> tart	Starts automatic detection when clicked.
D	<u>A</u> bort	Aborts automatic detection.
E	<u>N</u> ext>	Proceeds to "Inverter Selection".
F	< <u>B</u> ack	Returns to "Inverter Setting Method".
G	Cancel	Disables the settings and closes Easy Setup.
H	Help	Displays Help window.

4.2.6 Inverter selection

Click [Register System Setting] to register the system setting, and then parameter setting becomes available. Choose an inverter (station number) for parameter setting, and click [Next]. After parameter setting is finished, the window returns to "Inverter Selection" again. To configure parameters on multiple devices, return to this screen and select another inverter (station number) after you have finished configuring parameters on a particular inverter.

Click [Finish] to close Easy Setup, and proceeds to the Main frame window.

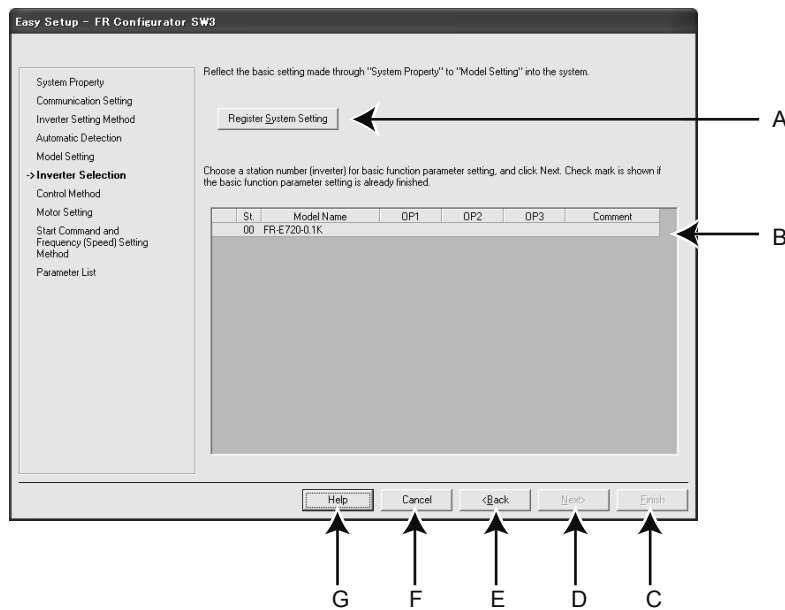

No.	Name	Function and description
A	Register <u>S</u> ystem Setting	Register the system setting configured in Easy Setup.
B	Inverter selecting field	Shows the inverter reflected into the system setting. Choose a station number for parameter setting, and click [Next]. A check mark is displayed on the station number if the parameter setting has been already configured. (Click [Register System Setting] to register the system setting first, and the field becomes available.)
C	<u>F</u> inish	Click to close Easy Setup, and proceeds to the Main frame window.
D	<u>N</u> ext>	Proceeds to "Control Method".
E	< <u>B</u> ack	Returns to "Model Setting", "Automatic Detection", or "Parameter List".
F	Cancel	Disables the settings and closes Easy Setup.
G	Help	Displays Help window.

4.2.7 Control method

From the "Control Method" screen, set a control method of the inverter selected in "Inverter Selection" window. Select the control method, and click [Next].

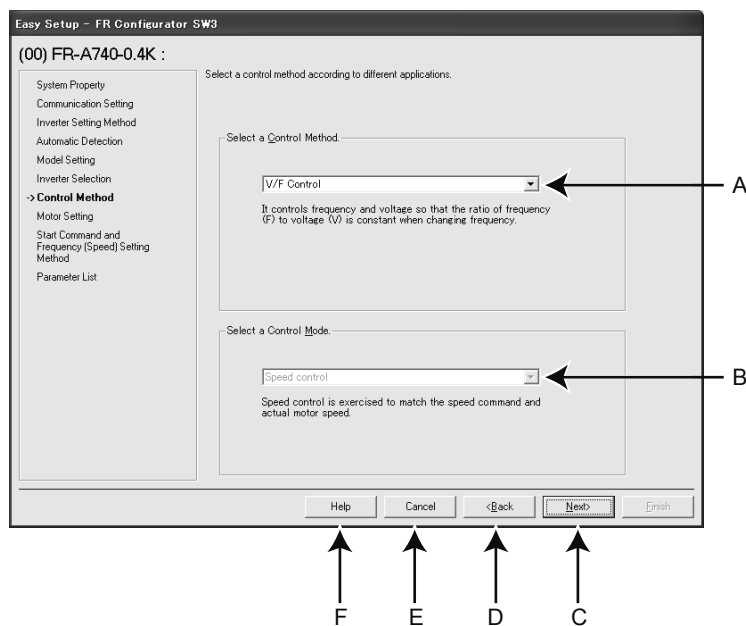

(Example of FR-A700)

No.	Name	Function and description
A	Select a <u>C</u> ontrol Method.	Select the control method.
B	Select a Control <u>M</u> ode.	Select the control mode. (FR-A700, A701, E700EX only)
C	<u>N</u> ext>	Proceeds to "Motor Setting".
D	< <u>B</u> ack	Returns to "Inverter Selection".
E	Cancel	Disables the settings and closes Easy Setup.
F	Help	Displays Help window.

* Some models have fixed settings.

4.2.8 Motor setting

Adjust the motor settings of the inverter. Click [Next] after inputting the motor information.

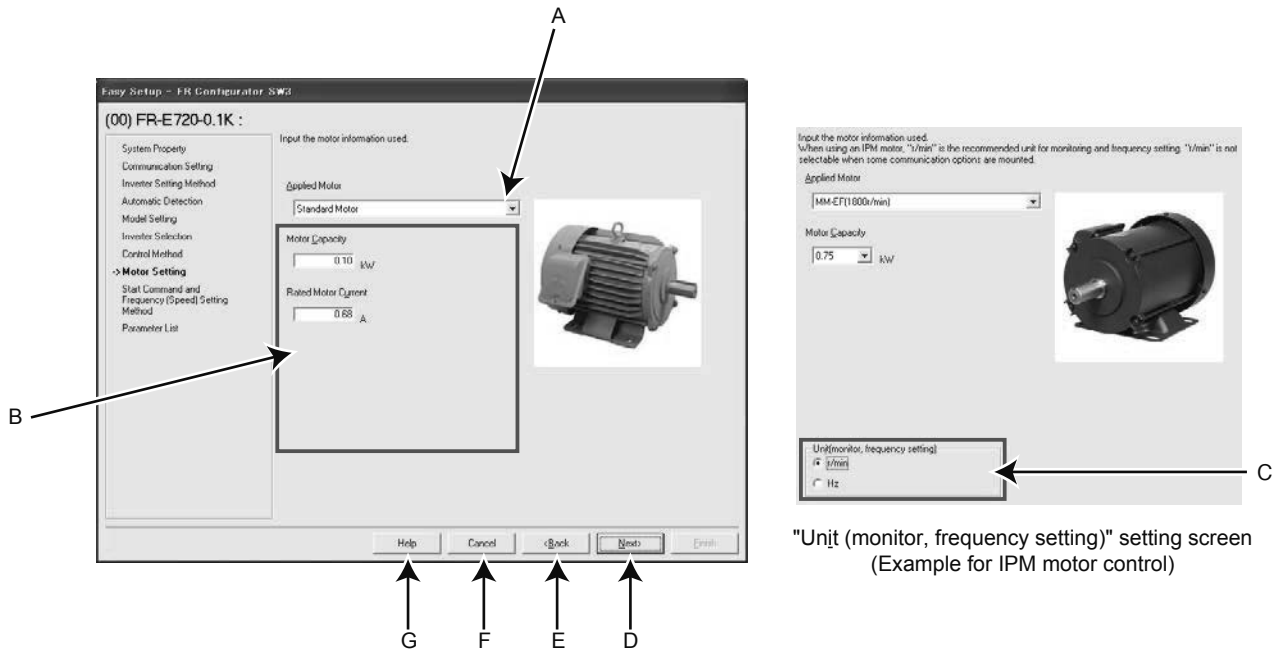

No.	Name	Function and description
A	Applied Motor	Select a type of motor. Selectable motor types are different according to the control method selected in "Control Method" window (or Pr. 71 setting) .
B	Motor information	Fill in the motor information. Required motor information to fill in is different according to the control method setting selected in "Control Method" window.
C	Unit (monitor, frequency setting)	Change the Hz unit in the monitor display and the frequency setting to rpm when necessary. This section is enabled when "IPM motor control" or "PM sensorless vector control" has been selected in the "Control Method" window. (According to the mounted communication option, the unit for monitor display and frequency setting may always be Hz.)
D	Next>	Proceeds to "Start Command and Frequency (Speed) Setting Method".
E	<Back	Returns to "Control Method".
F	Cancel	Disables the settings and closes Easy Setup.
G	Help	Displays Help window.

* Some models have fixed settings.

4.2.9 Start command and frequency (speed) setting method

Select an input method of start command and frequency (speed) setting.

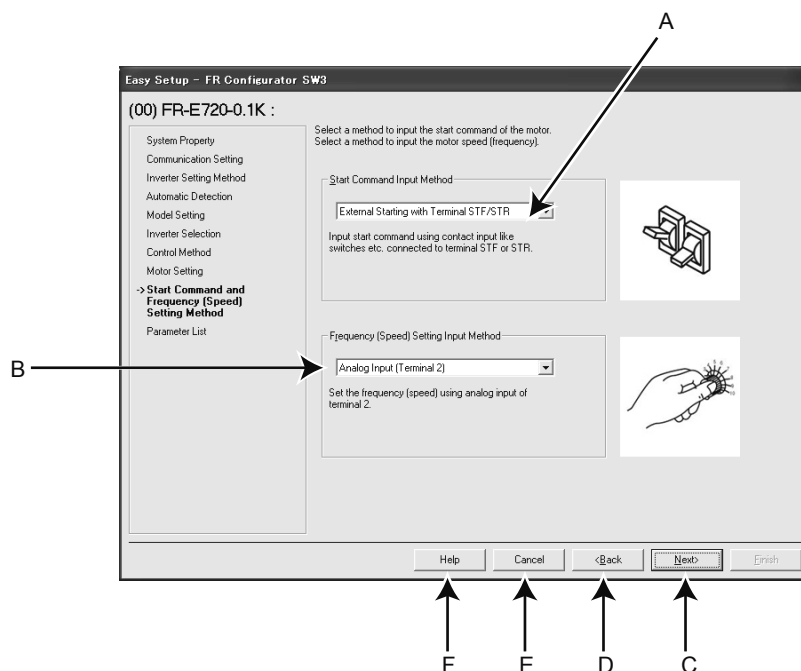

No.	Name	Function and description
A	<u>S</u> tart Command Input Method	Select the start command input method of the inverter.
B	F <u>r</u> equency (Speed) Setting Input Method	Select the frequency (speed) setting input method of the inverter.
C	<u>N</u> ext>	Proceeds to "Parameter List".
D	< <u>B</u> ack	Returns to "Motor Setting".
E	Cancel	Disables the settings and closes Easy Setup.
F	Help	Displays Help window.

4.2.10 Parameter List

After the required items are all set, parameter setting is configured based on the input setting. Parameter name and configured value are displayed in the Parameter List. To write the parameter setting to the inverter, write from the Parameter List in the Main frame.

Click [Next] to return to "Inverter Selection" window. To close Easy Setup, click [Finish] in "Inverter Selection" window. To set parameters for several inverters, select another inverter in "Inverter Selection" and set parameters.

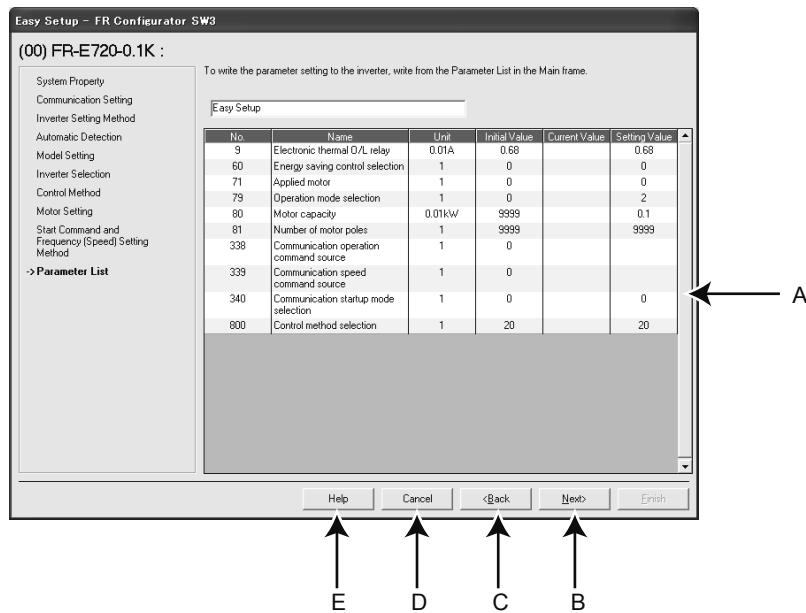

No.	Name	Function and description
A	Parameter setting field	Shows the parameter setting configured by Easy Setup in the list.
B	Next>	Proceeds to "Inverter Selection".
C	<Back	Returns to "Start Command and Frequency (Speed) Setting Method".
D	Cancel	Disables the settings and closes Easy Setup.
E	Help	Displays Help window.

4.3 Parameter List operations

4.3.1 Parameter List functions

"Parameter List" has the following functions.

- Showing parameters (all list, functional, individual, changed parameter, verification result parameter)
- Editing individual list
- Reading and batch reading of parameter setting value
- Input, writing and batch writing of parameter setting value
- Parameter clear and all parameter clear
- Parameter verification (verifies parameter values set on FR Configurator and values already written into the inverter)
- Parameter searching
- File output of parameter verification results, batch read, and batch write
- Writing of comment
- Parameter copy (use import/export.)

Select [Parameter List] under [View] menu, or click [Pr. List] on the tool bar to display "Parameter List".

The functions available in "Parameter List" are different between ONLINE or OFFLINE. (○: Available, —: Not available)

Function	ONLINE	OFFLINE
All Parameter Clear	○	—
Parameter Clear	○	—
Batch Read	○	—
Batch Write	○	—
Verification	○	—
Read	○	—
Write	○	—
Input of parameter setting value	○	○
Edit Individual List	○	○
Search	○	○
Display list selection	○	○
Writing of comment	○	○

4.3.2 Read (Batch Read), write (Batch Write) and verification

Performing Read or Write gains access to inverter parameter, and parameter reading and writing is performed. Performing Verification verifies the parameter values set on FR Configurator and the ones already written in the inverter. Click [Batch Read], [Batch Write], [Verification], [Read] or [Write] to display the following dialog.

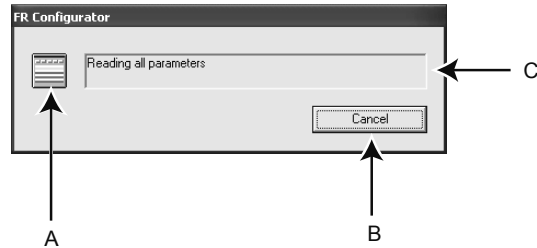

No.	Name	Function and description
A	Icon display during access	Icon display switches during parameter access. 
B	Cancel	Click to cancel batch read, batch write or verification. If [Cancel] is clicked, access is canceled and the data already processed are displayed.
C	Message	Shows a message during parameter access.

After verification, the following dialog appears. The results can be saved as a text file. (The dialog also appears at reading errors and writing errors.)

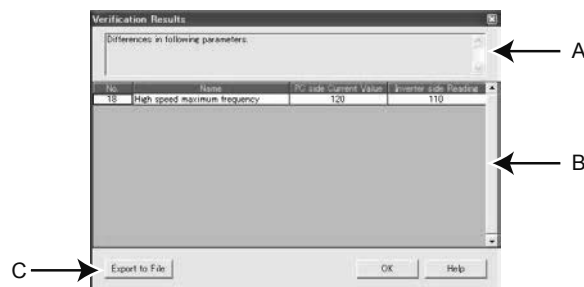



No.	Name	Function and description	
A	Result	Shows result message.	
B	Result list	Read	Shows the parameter number, name, initial value, and error number of the reading error parameters.
		Write	Shows the parameter number, name, data, and error number of the writing error parameters.
		Veri- fication	If the parameter setting value in FR Configurator (current value in the PC) is different with the parameter setting value written in the inverter (read value from the inverter), the parameter numbers, names, mismatched current values in the PC, and inverter read values are displayed.
C	Export to File	Saves the result in text format.	

4.3.3 Parameter clear and all parameter clear

Performing parameter clear or all parameter clear can initialize parameter setting values.

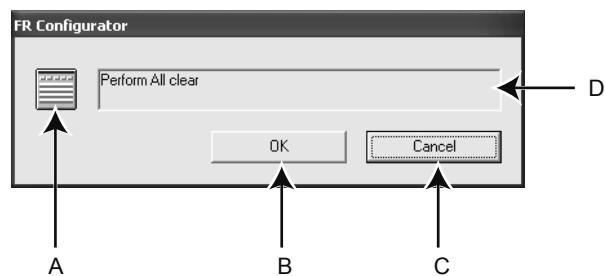
Click [Parameter Clear] or [All clear] to display the following dialog to confirm the parameter clear or all parameter clear. Refer to the Inverter Instruction Manual for the availability of parameter clear and all parameter clear for each parameter.



No.	Name	Function and description
A	Icon display of clearing	Icon display switches during parameter clear. 
B	OK	Click to perform parameter clear. (The color turns gray during parameter clear, and unavailable to use.)
C	Cancel	Click to cancel parameter clear. (The color turns gray during parameter clear, and unavailable to use.)
D	Message	Shows a message to confirm parameter clear, and shows a message during parameter clear.

Chapter 5

Inverter external connections

Inverters can be easily connected to GOTs and programmable controllers.

This chapter describes external connections that make using inverters even easier to use.

5.1 Connecting GOT with the inverter

This document describes the procedure to establish a peer-to-peer connection with Mitsubishi general-purpose inverter FR-E700 series and Mitsubishi GOT2000 series GT2708.

Refer to specific manuals for information on connecting other inverters and GOTs.

5.1.1 Function overview

GOT is an acronym for Graphic Operation Terminal.

Hardware switches and lamps installed to a conventional control panel have been replicated in software and combined with a touch panel display device to enable viewing of information and device operation via the monitor screen. The GOT can connect and send commands to up to 31 inverters via RS-485 communication. The GOT is equipped with USB ports located in the front so that doors do not have to be opened when performing inverter maintenance. The USB port on the GOT can be used to connect inverters without USB ports to PCs and use FR Configurator. Parameter configuration backups to SD cards can be performed with GOT2000 or later devices, which enables you to replace your Mitsubishi general-purpose inverter of the same type and restore the configuration saved on the SD card to the new inverter. This backup and restore functionality also significantly reduces time to load data into devices and equipment used for mass production.

5.1.2 System configuration

When connecting to one inverter

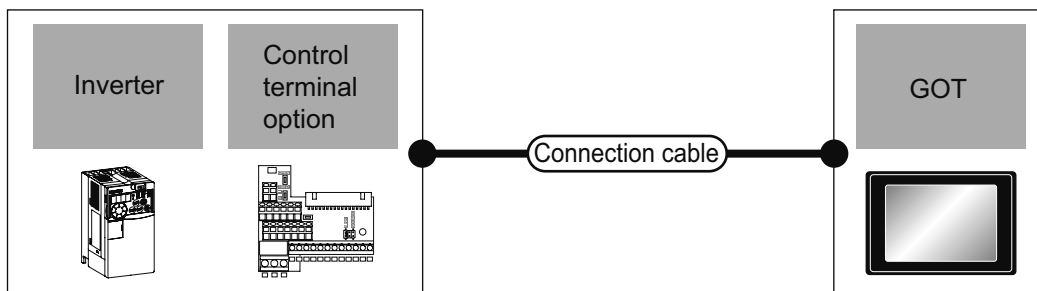

Inverter			Connection cable		GOT		Number of connectable equipment
Model name	Control terminal option	Communication type	Connection diagram number	Max. distance	Option device	Model	
FREQROL-E700	-	RS-485	RS485 connection diagram	500m	-(Built into GOT)	GT 27 GT 25	1 GOT for 1 inverter
					GT15-RS4-9S	GT 27 GT 25	
					GT10-C02H-9SC	GT 21 ^{04RS} GT 21 ^{03P} RA	

5.1.3 Cable connection diagram

Use an RS-485 cable to make the connection. Make sure cables are no longer than 500m if you make your own cable. Connect the connector on the inverter side of the cable into the PU port. Connect the GOT side of the cable into the D-Sub (subminiature) 9-pin.

Inverter connector

- Pin layout in the PU port

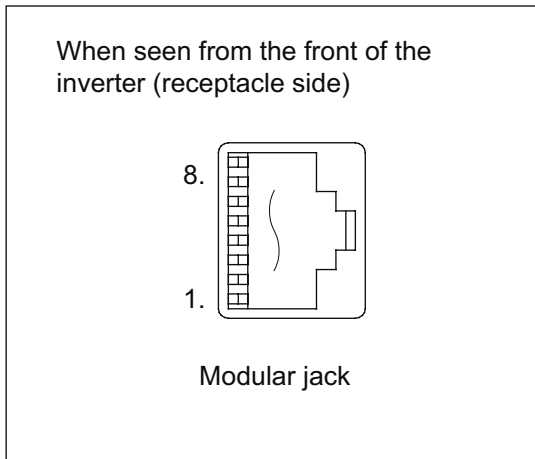

GOT connector

- D-Sub (subminiature) 9-pin

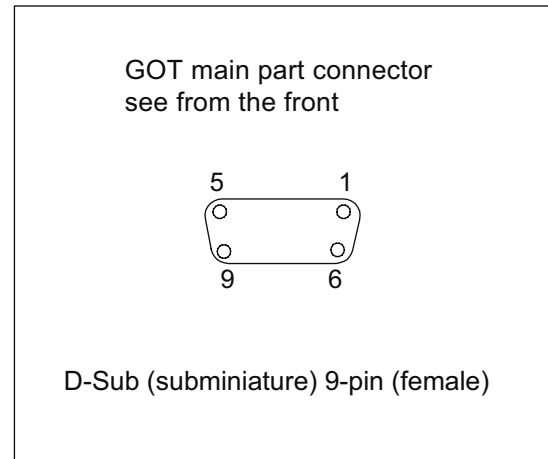

The following diagram shows the connection between the GOT and the inverter.

Wiring diagram

- RS-485 connection diagram

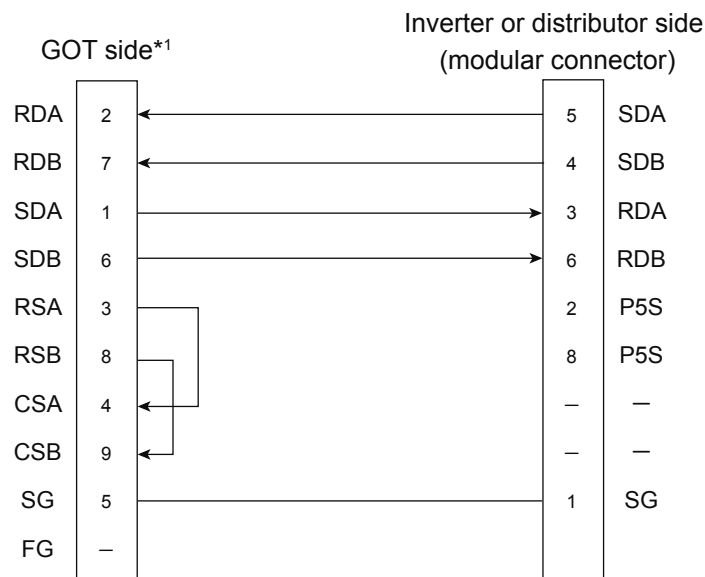

*1 Set the terminating resistor to "Disable".

5.1.4 Inverter communication settings

Communication settings

Make the communication settings of the inverter.

Be sure to perform the inverter reset after updating each parameter.

- **Communication port and corresponding parameters**

GOT connection destination	Parameters corresponding to inverter
PU connector	Pr.79, Pr.117 to Pr.124, Pr.340, Pr.342, Pr.549
FR-E7TR (RS-485 terminal block)	

- **Communication settings of the inverter**

Set the following parameters using the PU (parameter unit).

Do not change these parameters, even though they can be monitored from the GOT. If they are changed, communication with the GOT is disabled.

Setting item*1	Pr.	Setting	Contents of setting
PU communication station number	Pr.117	0 to 31	Station number setting
PU communication speed*2	Pr.118	192*3	19200bps
PU communication stop bit length*2	Pr.119	10	Data length: 7bit Stop bit length: 1bit
PU communication parity check**2	Pr.120	1	Odd
Number of PU communication retries	Pr.121	9999	The inverter will not come to an alarm stop.
PU communication check time interval	Pr.122	9999	Communication check suspension
PU communication wait time setting	Pr.123	0	0ms
PU communication CR/LF selection	Pr.124	1*3	With CR, without LF
Protocol selection	Pr.549	0*3	Mitsubishi inverter protocol
Operation mode selection	Pr.79	0*3	External operation mode when power is first turned on
Communication startup mode selection	Pr.340	1	NET operation mode
Communication EEPROM write selection	Pr.342	0*3	Written to RAM and EEPROM

*1 Setting items are parameter names described in the manual of FREQROL-E700 series.

*2 Settings on the GOT can be changed.

When changing the settings on the GOT, be sure to change the parameters on the inverter to correspond with the GOT settings.

*3 Inverter initial values (no need to change)

5.1.5 GOT communication settings

The GOT needs the dedicated software "GT Designer3".



Set the channel of the connected equipment.

1. Select [Common setting] → [Controller Setting] from the menu.

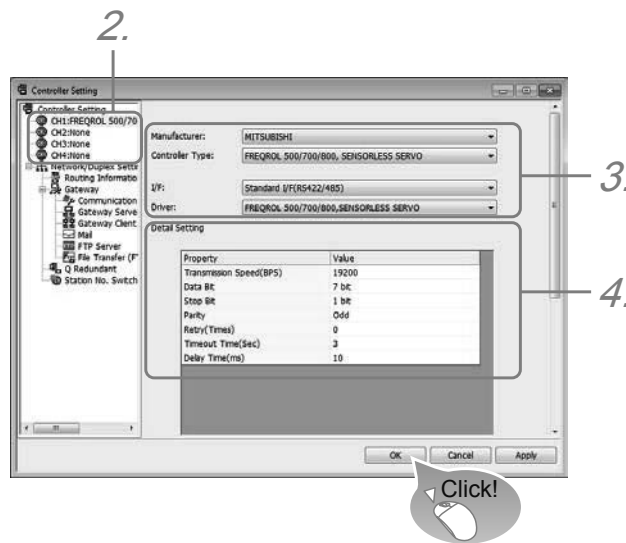

5

2. The Controller Setting window is displayed. Select the channel to be used from the list menu.
3. Set the following items.
 - Manufacturer: Mitsubishi Electric
 - Controller Type: FREQROL-E700
 - I/F: RS-485
 - Driver: [FREQROL 500/700/800, SENSORLESS SERVO]

4. Detailed settings are displayed after the manufacturer, controller type, I/F, and driver are configured.

Item	Description	Range
Baud rate	Set this item when change the baud rate used for communication with the connected equipment. (Initial value: 19200bps)	9600bps, 19200bps, 38400bps, 57600bps, 115200bps
Data length	Set this item when change the data length used for communication with the connected equipment. (Initial value: 7bits)	7bits/8bits
Stop Bit	Specify the stop bit length for communications. (Initial value: 1bit)	1bit/2bits
Parity	Specify whether or not to perform a parity check, and how it is performed during communication. (Initial value: odd)	None Even Odd
Retry	Set the number of retries to be performed when a communication timeout occurs. (Initial value: 0time)	0 to 5times
Timeout Time	Set the time period for a communication to time out. (Initial value: 3sec)	1 to 30sec
Delay Time	Set this item to adjust the transmission timing of the communication request from the GOT. (Initial value: 10ms)	0 to 300ms

* Initial values are the initial settings of parameters from the factory.
Although the inverter can be operated at the initial settings, configure parameters in accordance with your usage environment.

5.2 Connecting MELSEC iQ-F series with the inverter

This document describes the procedure to establish a peer-to-peer connection with the Mitsubishi general-purpose inverter FR-E700 series and the Mitsubishi programmable controller FX5U CPU module. Refer to specific manuals for information on connecting other inverters and programmable controllers.

5.2.1 Function overview

Inverter communication function can be used to connect FX5 programmable controllers and inverters to monitor, send commands to, and read/write parameters for up to 16 devices via RS-485 communication.

- Inverters can be monitored, commands can be sent, and parameters can be read/written.
- The total maximum distance is 1200m. (only with configurations including FX5-485ADP)

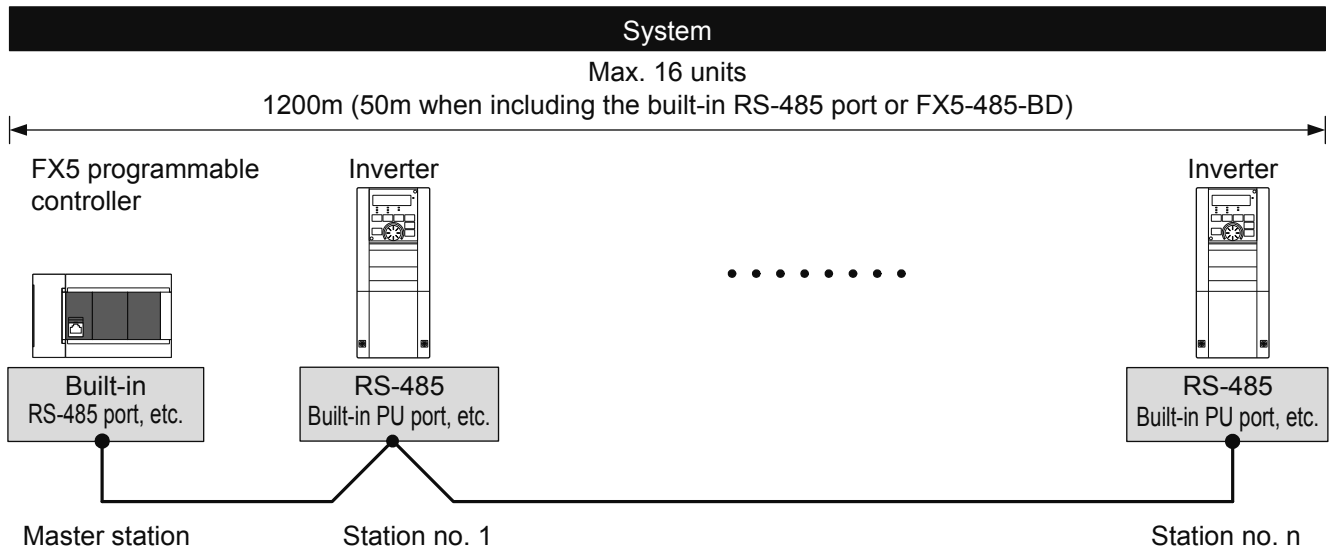

5.2.2 System configuration

This section provides an overview of the system configuration needed to use inverter communication. Inverter communication is used over the built-in RS-485 port, communication board, and communication adapter. Serial ports assignments are hard-coded as follows regardless of the system configuration.

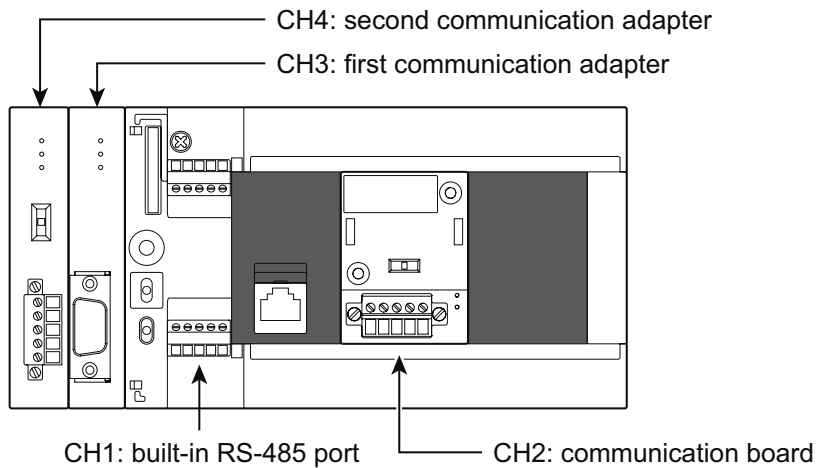

Depending on the connection method, use either a 10BASE-T or shielded twisted pair cable to connect with devices over RS-485 communication.

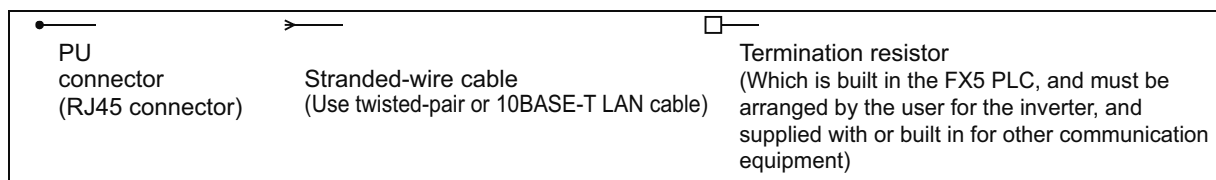

PU connector

- Peer-to-peer connections

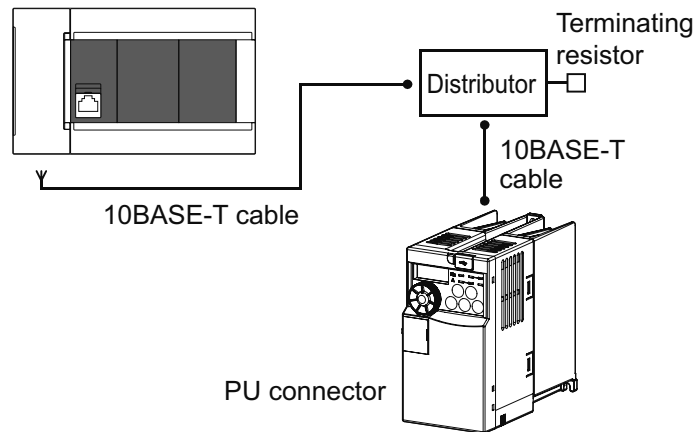

POINT

- Use a switch as termination resistors cannot be connected to the inverter side of the connection.
- Connections cannot be made using the built-in Ethernet port in the CPU module.

5.2.3 Connecting terminating resistors

Configure and connect a terminating resistor to the inverter farthest from the FX5 programmable controller.

FX5 programmable controller side of connections

The built-in RS-485 port, the FX5-485-BD and the FX5-485ADP have internal terminating resistors. Set the terminating resistor selector switch to 110Ω.

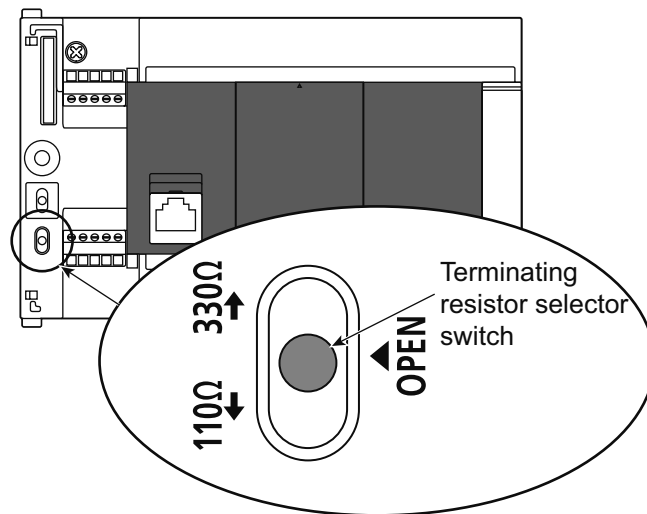

Inverter side of connections

Reflections may interfere with communication depending on transmission speed and distance. Connect a terminating resistor if these reflections begin to interfere with communication.

• PU connector

The user must prepare one terminating resistor of 100Ω, 1/2W.

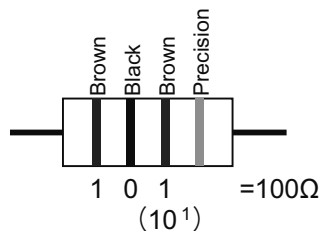

- Connect the terminating resistor between number 3 pin (RDA) and number 6 pin (RDB).
- Use a switch as a terminating resistor cannot be installed to PU connectors.
- Connect the terminating resistor to only the inverter farthest from the programmable controller.

5.2.4 Cable wiring diagram

PU connector

E700 series

Connecting one inverter (4-wire type)

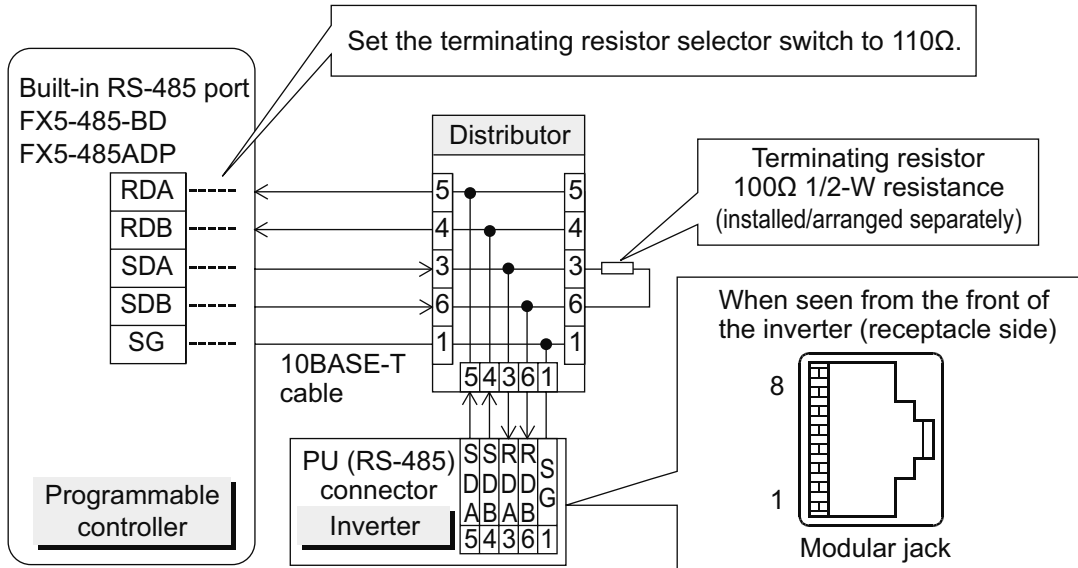

Connecting multiple inverters (up to 16; 4-wire type)

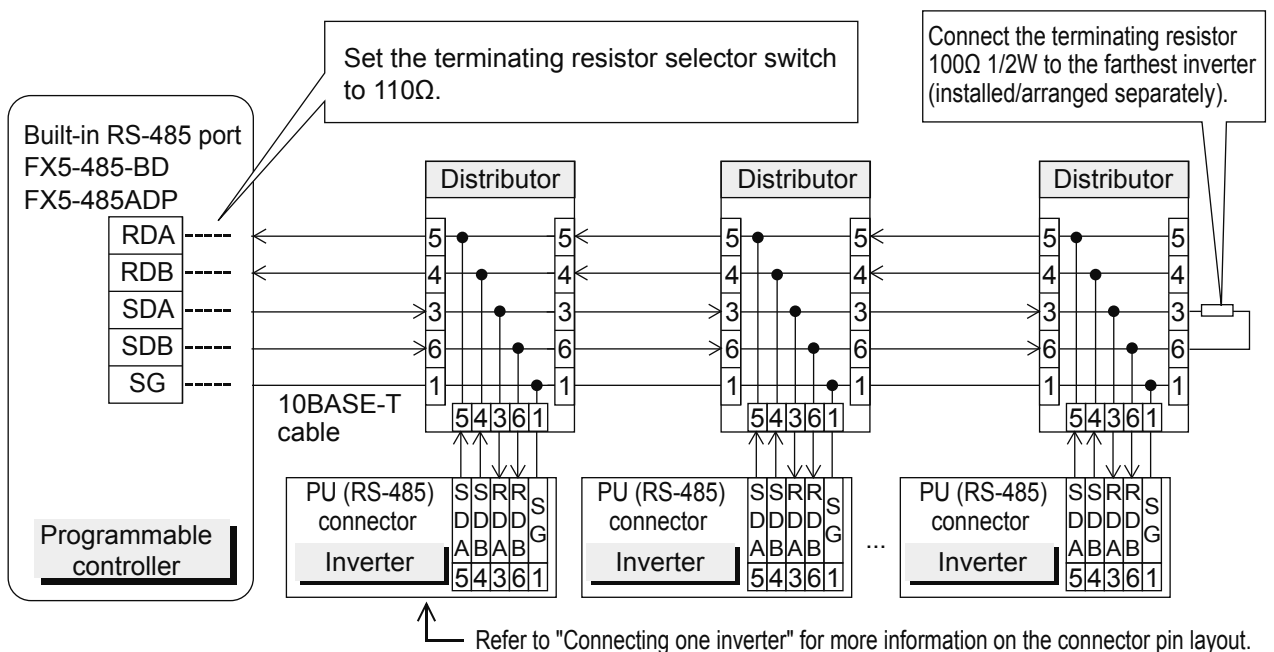

Connecting one inverter (2-wire type, E700 series only)

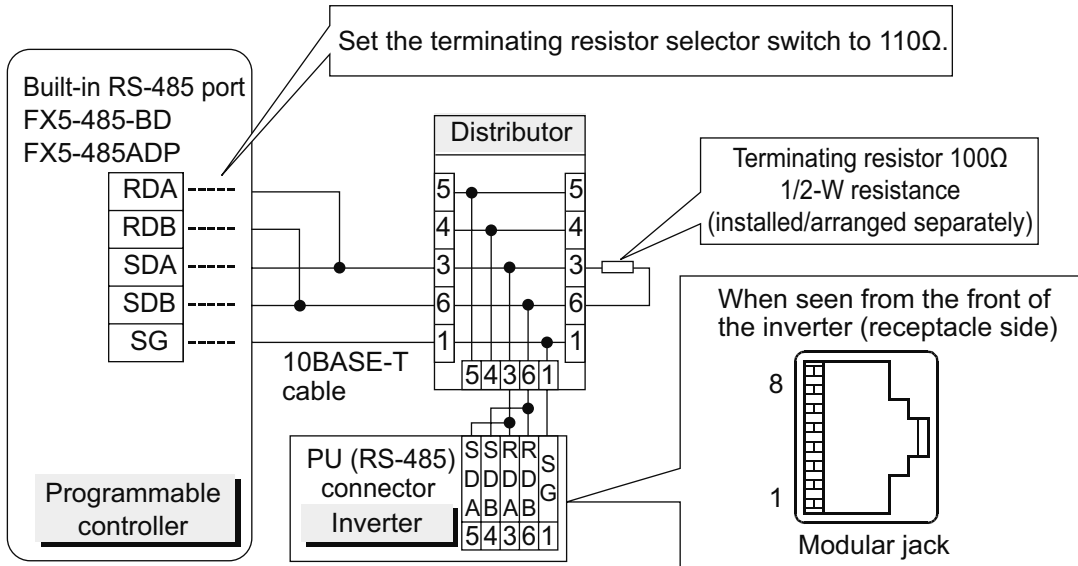

Connecting multiple inverters (maximum of 16 units, 2-wire type, E700 series only)

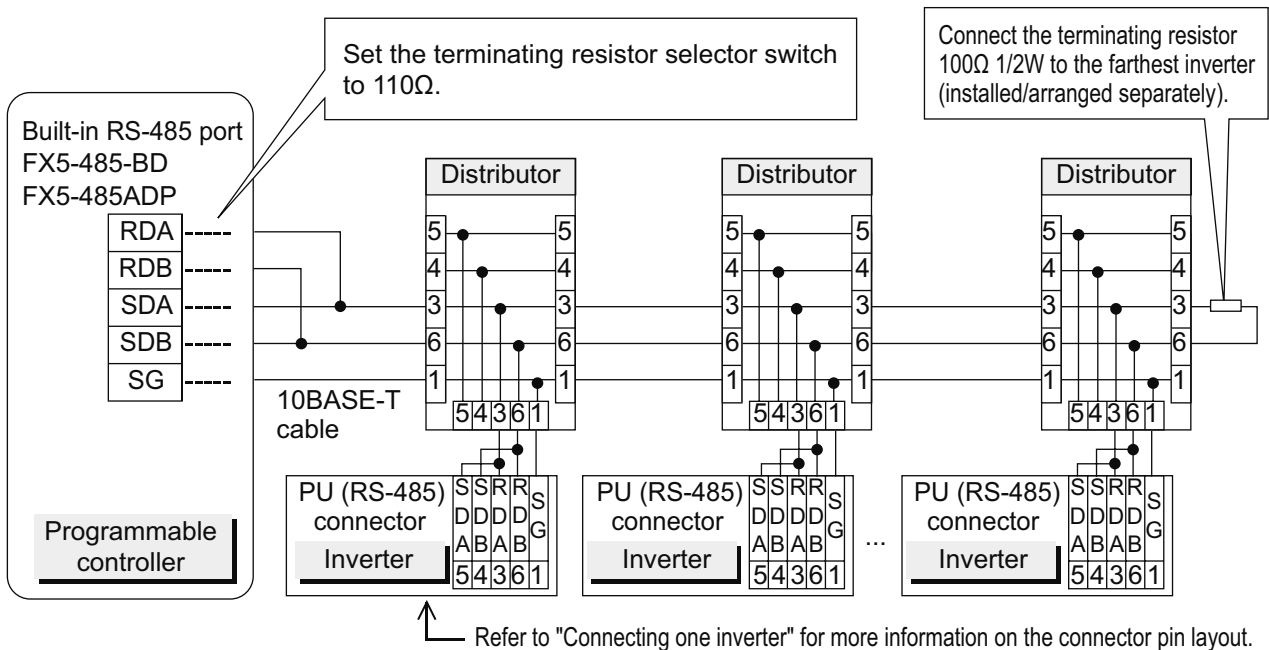

5.2.5 Inverter communication settings

Configure communication parameters on the inverter parameter unit (PU) in advance before connecting the inverter to the programmable controller. Be sure to perform the inverter reset after updating each parameter.

Communication setting details (required parameters)

The following table lists the parameters that must be configured.

Pr.	Parameter	Setting	Contents of setting
Pr.117	PU communication station number	0 to 31	Up to 16 inverters can be connected
Pr.118	PU communication speed	48	4800bps
		96	9600bps
		192	19200bps
		384	38400bps
Pr.119	PU communication stop bit length	10	Data length: 7 bits Stop bit: 1 bit
Pr.120	PU communication parity check	2	Even parity
Pr.123	PU communication waiting time setting	9999	Configured with communication data
Pr.124	PU communication CR/LF selection	1	With CR, without LF
Pr.79	Operation mode selection	0	External operation mode when power is first turned on
Pr.549	Protocol selection	0	Mitsubishi inverter protocol (computer link)
Pr.340	Communication startup mode selection	1 or 10	1: Network operation mode 10: Network operation mode (the PU operation mode and network operation mode can be changed from the operation panel)

5.2.6 FX5 programmable controller communication settings

Communication parameters settings for this function are configured using GX Works 3. GX Works 3 is programming software for programmable controllers. Refer to the GX Works 3 Operating Manual for more information on GX Works3.

Parameter settings vary depending on the units used. Operation of each unit is described below.

Built-in RS-485 port (CH1)

Navigation window, parameters, FX5UCPU, unit parameters, 485 serial port

Screen display

Selecting [Inverter Communication] as the protocol displays the following screen.

Basic setting

Item	Setting
Communication Protocol Type	Set communication protocol type.
Communication Protocol Type	Inverter Communication
Advanced Settings	Set detailed setting.
Data Length	7bit
Parity Bit	Even
Stop Bit	1bit
Baud Rate	9,600bps

Specific settings

Item	Setting
Response Waiting Time	Set response waiting time.
Response Waiting Time	100 ms

SM/SD settings

Item	Setting
Latch Setting	Set the latch of SM/SD device.
Advanced Settings	Do Not Latch
Response Waiting Time	Do Not Latch
FX3 Series Compatibility	The SM/SD device of FX3 series compatibility.
SM/SD for Compatible	Disable

5.3 External potentiometer operation

5.3.1 Analog configuration of frequency (voltage and current input)

Inverters require frequency and start commands. Frequency commands (set frequency) determine the rotation speed of the motor. Turning on the start command starts rotating the motor.

POINT

- The operation panel (RUN) is used to issue start commands.
- Frequency commands are issued using the potentiometer (frequency setting potentiometer, voltage input) or current inputs of 4-20mA.
- Set Pr. 79 Operation mode selection to "4" (External/PU operation mode 2).

[Connection Ex.: voltage input]
(The inverter supplies 5V power to the frequency setting potentiometer. (Terminal 10))

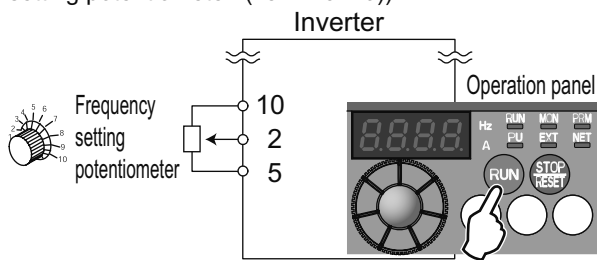



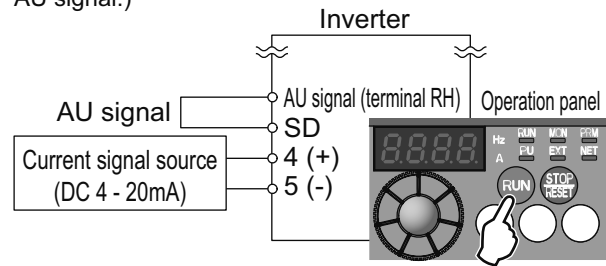



[Connection Ex.: current input]
(Assign one parameter between Pr. 178 - 184 to the AU signal.)



Operation example

Operate at 60Hz.

Operation	
1	Screen at power-ON The monitor display appears.
2	AU signal assignment (current input; proceed to step 3 for voltage input) Set Pr. 160 to "0" to enable extended parameters. Set "4" in any of Pr.178 to Pr.184 to assign the AU signal. Turn on the AU signal.
3	Quick setup mode settings Press  and  together for 0.5s. "79 - -" appears and the [PRM] indicator flashes.
4	Operation mode selection Turn  until 79 - 4 appears. The [PU] and [PRM] indicators flash.
5	Operation mode settings Press  to finalize the setting. (Set Pr. 79 to "4".) "79 - 4" and "79 - -" flash alternately. [PU] and [EXT] indicators are on.
6	Start Press  . [RUN] flashes quickly as no frequency command has been issued.
7	Acceleration → constant speed To set with voltage input, slowly turn the potentiometer (frequency setting potentiometer) completely clockwise. To set with current input, input 20mA of current. The frequency value in the display increases in accordance with the Pr. 7 Acceleration time and "60.00" (60.00Hz) appears. The [RUN] indicator is on during forward rotation and slowly flashes during reverse rotation.
8	Deceleration To set with voltage input, slowly turn the potentiometer (frequency setting potentiometer) completely counter-clockwise. To set with current input, input 4mA of current. The frequency value in the display increases in accordance with the Pr. 8 Deceleration time, "000" (00.00Hz) appears, and the motor stops operating. The [RUN] indicator flashes quickly.
9	Stop Press  . [RUN] turns OFF.

POINT

- The frequency is initially set to 60Hz when the frequency setting potentiometer is turned completely clockwise to its maximum setting (voltage input). (Change with Pr. 125)
- Set Pr. 73 analog input selection to "0" when a signal of 10VDC is input into terminal 2. The initial value is "1 (0-5V input)".
- The frequency is initially set to 60Hz when 20mA of current is input.

Inverter review questions

Chapter 6

Review

Let's review the material covered up to this point.

This chapter contains review questions on the material covered up to this point.

Review 1 Belt conveyor control

Configure the parameters necessary to satisfy the following belt conveyor control specifications and conditions.

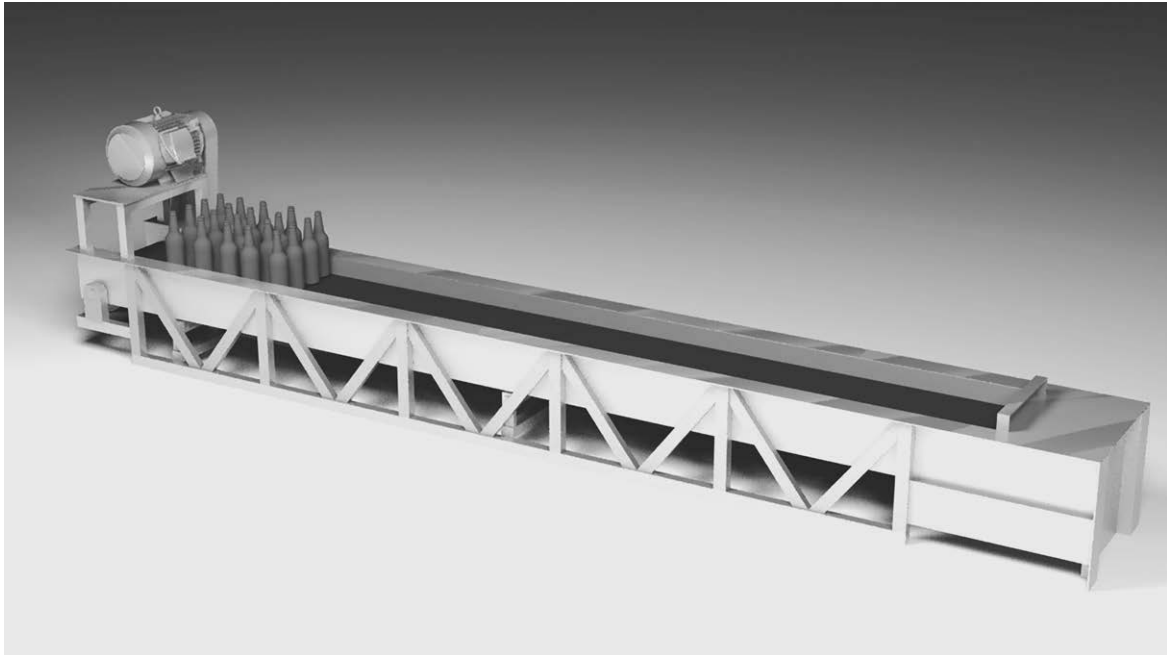

Control specifications

- 1.** The conveyor should start and stop slowly so that bottles do not fall off.
Configure starts and stops to take 10 seconds.
- 2.** The rated frequency of the motor is 60Hz.
- 3.** The upper-limit and lower-limit motor frequencies should be left at the initial values.

Review 2 Writing parameters using FR Configurator

Use FR Configurator to perform the following operations.

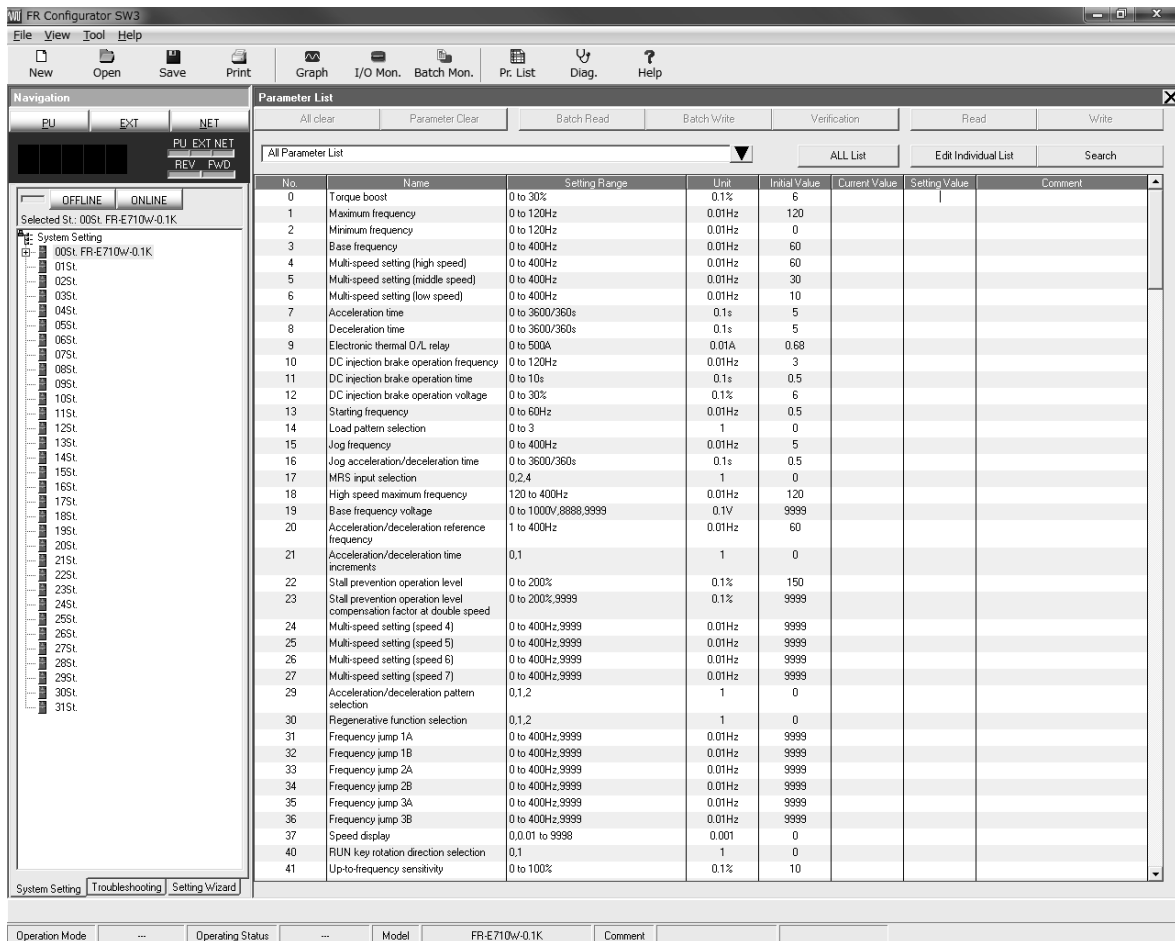

Control specifications

1. Load the parameter list as a "Batch Read" operation.
2. Clear all parameters.
3. Change the upper-limit motor frequency to 100Hz and the lower-limit frequency to 20Hz, and then perform a "Batch Write" operation.

Review 3 Comprehension test

Question 1

The following procedure is used to change parameter "Pr. 8" from the initial value of 5 to 10 while the device is in parameter configuration mode.

Fill in the blanks from A-H so that the procedure is correct.

* The same option may be used more than once.

- (1). While in external operation mode, press (A) (B) to switch to PU operation mode.
- (2). Press (C) (D) to switch to parameter configuration mode.
- (3). "P. 0" appears on the monitor.
- (4). Turn (E) to select parameter "Pr. 8".
- (5). Press (F) to display the initial value of "5" for "Pr. 8".
- (6). Turn (G) to change the value from "5" to "10".
- (7). Press (H) to finalize the new setting of "10".
- (8). "F" and "10" flashes, which completes the parameter change.

A (), B (), C (), D (), E ()
F (), G (), H ()

RUN key one time	STOP/RESET key two times	MODE key three times	SET key	PU/EXT key	M Dial
---------------------	-----------------------------	-------------------------	---------	------------	--------

Question 2

Match the following types of fault displays with the correct description.

A. Error message B. Warning C. Minor failure D. Major fault

1. The inverter does not trip even if a warning is displayed. However, lack of appropriate measures may lead to a major fault.
2. When the protective function is activated, the inverter trips and a fault signal is output.
3. A message regarding an operational errors of the operation panel or configuration errors of the parameter unit (FR-PU04/FR-PU07) is displayed.
The inverter does not trip.
4. The inverter does not trip. You can also output a minor failure signal by making parameter setting.

(A with), (B with), (C with), (D with)

Question 3

Select the appropriate operation panel operation to perform the following operations.

- Selecting frequency and other settings..... ()
- Finalizing frequency and other settings..... ()
- Starting motor operation..... ()
- Stopping motor operation..... ()
- Setting mode switchover ()
- External/PU operation mode switchover..... ()
- Switching monitor displays (output frequency/output current/output voltage)..... ()

A. RUN key B. STOP/RESET key C. MODE key D. SET key E. PU/EXT key
F. M Dial G. SET key

Question 4

What are the correct input values for parameters "Pr. 3 Base frequency" and "Pr. 19 Base frequency voltage" to satisfy the following specifications so that the inverter operates at the optimal state.

<Specifications>

- Motor type: High-speed motor
- Motor base frequency: 50Hz
- Motor base frequency voltage: 200V

"Pr. 3: Base frequency": () Hz

"Pr. 19: Base frequency voltage": () V

Answers

Question 1

A (PU/EXT key), B (one time), C (MODE key), D (one time)
E (M Dial), F (SET key), G (M Dial), H (SET key)

Question 2

(A with 3.), (B with 1.), (C with 4.), (D with 2.)

Question 3

- Selecting frequency and other settings..... (F)
- Finalizing frequency and other settings..... (G)
- Starting motor operation..... (A)
- Stopping motor operation..... (B)
- Switching in and out of configuration mode..... (C)
- Switching in and out of external/PU operation mode..... (E)
- Switching monitor displays (output frequency/output current/output voltage)..... (D)

Question 4

"Pr. 3: Base frequency": (50) Hz

"Pr. 19: Base frequency voltage": (200) V

Appendix 1 Parameter List (FR-E700)

Parameters significantly vary depending on model of device. The parameter list for the FR-E700 model is included in this document.

Make sure to read the specific manual for your device if your environment contains different devices.

Parameter	Name	Setting range	Initial value
0	Torque boost	0 to 30%	6/4/3/2% ^{*1}
1	Upper-limit frequency	0 to 120Hz	120Hz
2	Lower-limit frequency	0 to 120Hz	0Hz
3	Base frequency	0 to 400Hz	60Hz
4	Multi-speed setting (high speed)	0 to 400Hz	60Hz
5	Multi-speed setting (middle speed)	0 to 400Hz	30Hz
6	Multi-speed setting (low speed)	0 to 400Hz	10Hz
7	Acceleration time	0 to 3600/360s	5/10/15s ^{*2}
8	Deceleration time	0 to 3600/360s	5/10/15s ^{*2}
9	Electronic thermal O/L relay	0 to 500A	Inverter rated current
10	DC injection brake operation frequency	0 to 120Hz	3Hz
11	DC injection brake operation time	0 to 10s	0.5s
12	DC injection brake operation voltage	0 to 30%	6/4/2% ^{*3}
13	Starting frequency	0 to 60Hz	0.5Hz
14	Load pattern selection	0 to 3	0
15	Jog frequency	0 to 400Hz	5Hz
16	Jog acceleration/ deceleration time	0 to 3600/360s	0.5s
17	MRS input selection	0, 2, 4	0
18	High speed upper-limit frequency	120 to 400Hz	120Hz
19	Base frequency voltage	0 to 1000V, 8888, 9999	9999
20	Acceleration/ deceleration reference frequency	1 to 400Hz	60Hz
21	Acceleration/ deceleration time increments	0, 1	0
22	Stall prevention operation level	0 to 200%	150%
23	Stall prevention operation level compensation factor at double speed	0 to 200%, 9999	9999
24	Multi-speed setting (speed 4)	0 to 400Hz, 9999	9999

Parameter	Name	Setting range	Initial value
25	Multi-speed setting (speed 5)	0 to 400Hz, 9999	9999
26	Multi-speed setting (speed 6)	0 to 400Hz, 9999	9999
27	Multi-speed setting (speed 7)	0 to 400Hz, 9999	9999
29	Acceleration/ deceleration pattern selection	0, 1, 2	0
30	Regenerative function selection	0, 1, 2	0
31	Frequency jump 1A	0 to 400Hz, 9999	9999
32	Frequency jump 1B	0 to 400Hz, 9999	9999
33	Frequency jump 2A	0 to 400Hz, 9999	9999
34	Frequency jump 2B	0 to 400Hz, 9999	9999
35	Frequency jump 3A	0 to 400Hz, 9999	9999
36	Frequency jump 3B	0 to 400Hz, 9999	9999
37	Speed display	0 to 0,01 to 9998	0
40	RUN key rotation direction selection	0, 1	0
41	Up-to-frequency sensitivity	0 to 100%	10%
42	Output frequency detection	0 to 400Hz	6Hz
43	Output frequency detection for reverse rotation	0 to 400Hz, 9999	9999
44	Second acceleration/ deceleration time	0 to 3600/360s	5/10/15s ^{*2}
45	Second deceleration time	0 to 3600/360s, 9999	9999
46	Second torque boost	0 to 30%, 9999	9999
47	Second V/F (base frequency)	0 to 400Hz, 9999	9999
48	Second stall prevention operation current	0 to 200%, 9999	9999

Parameter	Name	Setting range	Initial value
51	Second electronic thermal O/L relay	0 to 500 A, 9999	9999
52	DU/PU main display data selection	0, 5, 7 to 12, 14, 20, 23 to 25, 52 to 57, 61, 62, 100	0
54	FM terminal function selection	1 to 3, 5, 7 to 12, 14, 21, 24, 52, 53, 61, 62	1
55	Frequency monitor reference	0 to 400Hz	60Hz
56	Current monitoring reference	0 to 500A	Inverter rated current
57	Restart coasting time	0, 0.1 to 5s, 9999	9999
58	Restart cushion time	0 to 60s	1s
59	Remote function selection	0, 1, 2, 3	0
60	Energy saving control selection	0, 9	0
61	Reference current	0 to 500A, 9999	9999
62	Reference value at acceleration	0 to 200%, 9999	9999
63	Reference value at deceleration	0 to 200%, 9999	9999
65	Retry selection	0 to 5	0
66	Stall prevention operation reduction starting frequency	0 to 400Hz	60Hz
67	Number of retries at fault occurrence	0 to 10, 101 to 110	0
68	Retry waiting time	0.1 to 360s	1s
69	Retry count display erase	0	0
70	Special regenerative brake duty	0 to 30%	0%
71	Applied motor	0, 1, 3 to 6, 13 to 16, 23, 24, 40, 43, 44, 50, 53, 54	0
72	PWM frequency selection	0 to 15	1
73	Analog input selection	0, 1, 10, 11	1
74	Input filter time constant	0 to 8	1
75	Reset selection/disconnected PU detection/PU stop selection	0 to 3, 14 to 17	14

Parameter	Name	Setting range	Initial value
77	Parameter write selection	0, 1, 2	0
78	Reverse rotation prevention selection	0, 1, 2	0
79	Operation mode selection	0, 1, 2, 3, 4, 6, 7	0
80	Motor capacity	0.1 to 15kW, 9999	9999
81	Number of motor poles	2, 4, 6, 8, 10, 9999	9999
82	Motor excitation current	0 to 500A (0 to ****), 9999 *5	9999
83	Rated motor voltage	0 to 1000V	200/400V *4
84	Rated motor frequency	10 to 120Hz	60Hz
89	Speed control gain (Advanced magnetic flux vector)	0 to 200%, 9999	9999
90	Motor constant (R1)	0 to 50Ω (0 to ****), 9999 *5	9999
91	Motor constant (R2)	0 to 50Ω (0 to ****), 9999 *5	9999
92	Motor constant (L1)	0 to 1000mH (0 to 50Ω, 0 to ****), 9999 *5	9999
93	Motor constant (L2)	0 to 1000mH (0 to 50Ω, 0 to ****), 9999 *5	9999
94	Motor constant (X)	0 to 100% (0 to 500Ω, 0 to ****), 9999 *5	9999
96	Auto tuning setting/status	0, 1, 11, 21	0
117	PU communication station number	0 to 31 (0 to 247)	0
118	PU communication speed	48, 96, 192, 384	192
119	PU communication stop bit length	0, 1, 10, 11	1
120	PU communication parity check	0, 1, 2	2
121	Number of PU communication retries	0 to 10, 9999	1
122	PU communication check time interval	0.01 to 999.8s, 9999	0
123	PU communication waiting time setting	0 to 150ms, 9999	9999

Parameter	Name	Setting range	Initial value
124	PU communication CR/LF selection	0, 1, 2	1
125	Terminal 2 frequency setting gain frequency	0 to 400Hz	60Hz
126	Terminal 4 frequency setting gain frequency	0 to 400Hz	60Hz
127	PID control automatic switchover frequency	0 to 400Hz, 9999	9999
128	PID action selection	0, 20, 21, 40 to 43, 50, 51, 60, 61	0
129	PID proportional band	0.1 to 1000%, 9999	100%
130	PID integral time	0.1 to 3600s, 9999	1s
131	PID upper limit	0 to 100%, 9999	9999
132	PID lower limit	0 to 100%, 9999	9999
133	PID action set point	0 to 100%, 9999	9999
134	PID differential time	0.01 to 10.00s 9999	9999
145	PU display language selection	0 to 7	0
146 ⁶	Built-in potentiometer switching	0, 1	1
147	Acceleration/ deceleration time switching frequency	0 to 400Hz, 9999	9999
150	Output current detection level	0 to 200%	150%
151	Output current detection signal delay time	0 to 10s	0s
152	Zero current detection level	0 to 200%	5%
153	Zero current detection time	0 to 1s	0.5s
156	Stall prevention operation selection	0 to 31, 100, 101	0
157	OL signal output timer	0 to 25s, 9999	0s
160	User group read selection	0, 1, 9999	0
161	Frequency setting/ key lock operation selection	0, 1, 10, 11	0

Parameter	Name	Setting range	Initial value
162	Automatic restart after instantaneous power failure selection	0, 1, 10, 11	1
165	Stall prevention operation level for restart	0 to 200%	150%
168	Parameter for manufacturer setting. Do not set.		
169			
170	Watt-hour meter clear	0, 10, 9999	9999
171	Operation hour meter clear	0, 9999	9999
172	User group registered display/ batch clear	9999, (0 to 16)	0
173	User group registration	0 to 999, 9999	9999
174	User group clear	0 to 999, 9999	9999
178	STF terminal function selection	0 to 5, 7, 8, 10, 12, 14 to 16, 18, 24, 25, 60 (Pr. 178), 61 (Pr. 179), 62, 65 to 67, 9999	60
179	STR terminal function selection		61
180	RL terminal function selection		0
181	RM terminal function selection		1
182	RH terminal function selection		2
183	MRS terminal function selection		24
184	RES terminal function selection		62
190	RUN terminal function selection		0, 1, 3, 4, 7, 8, 11 to 16, 20, 25, 26, 46, 47, 64, 90, 91, 93 (Pr. 190, Pr. 191), 95, 96, 98, 99, 100, 101, 103, 104, 107, 108, 111 to 116, 120, 125, 126, 146, 147, 164, 190, 191, 193 (Pr. 190, Pr. 191), 195, 196, 198, 199, 9999
191	FU terminal function selection	4	
192	A, B, C terminal function selection	99	
232	Multi-speed setting (8 levels of speed)	0 to 400Hz, 9999	9999
233	Multi-speed setting (9 levels of speed)	0 to 400Hz, 9999	9999

Parameter	Name	Setting range	Initial value
234	Multi-speed setting (10 levels of speed)	0 to 400Hz, 9999	9999
235	Multi-speed setting (11 levels of speed)	0 to 400Hz, 9999	9999
236	Multi-speed setting (12 levels of speed)	0 to 400Hz, 9999	9999
237	Multi-speed setting (13 levels of speed)	0 to 400Hz, 9999	9999
238	Multi-speed setting (14 levels of speed)	0 to 400Hz, 9999	9999
239	Multi-speed setting (15 levels of speed)	0 to 400Hz, 9999	9999
240	Soft-PWM operation selection	0, 1	1
241	Analog input display unit switchover	0, 1	0
244	Cooling fan operation selection	0, 1	1
245	Rated slip	0 to 50%, 9999	9999
246	Slip compensation time constant	0.01 to 10s	0.5s
247	Constant-power range slip compensation selection	0, 9999	9999
249	Earth (ground) fault detection at start	0, 1	0
250	Stop selection	0 to 100s, 1000 to 1100s, 8888, 9999	9999
251	Output phase loss protection selection	0, 1	1
255	Life alarm status display	(0 to 15)	0
256	Inrush current limit circuit life display	(0 to 100%)	100%
257	Control circuit capacitor life display	(0 to 100%)	100%
258	Main circuit capacitor life display	(0 to 100%)	100%
259	Main circuit capacitor life measuring	0, 1 (2, 3, 8, 9)	0
261	Power failure stop selection	0, 1, 2	0
267	Terminal 4 input selection	0, 1, 2	0
268	Monitor decimal digits selection	0, 1, 9999	9999
269	Parameter for manufacturer setting. Do not set.		
270	Stop-on contact control selection	0, 1	0

Parameter	Name	Setting range	Initial value
275	Stop-on contact excitation current low-speed multiplying factor	0 to 300%, 9999	9999
276	PWM carrier frequency at stop-on contact	0 to 9, 9999	9999
277	Stall prevention operation current switchover	0, 1	0
278	Brake opening frequency	0 to 30Hz	3Hz
279	Brake opening current	0 to 200%	130%
280	Brake opening current detection time	0 to 2s	0.3s
281	Brake operation time at start	0 to 5s	0.3s
282	Brake operation frequency	0 to 30Hz	6Hz
283	Brake operation time at stop	0 to 5s	0.3s
286	Droop gain	0 to 100%	0%
287	Droop filter time constant	0 to 1s	0.3s
292	Automatic acceleration/ deceleration	0, 1, 7, 8, 11	0
293	Acceleration/ deceleration separate selection	0 to 2	0
295	Magnitude of frequency change setting	0, 0.01, 0.1, 1, 10	0
296	Password lock level	0 to 6, 99, 100 to 106, 199, 9999	9999
297	Password lock/ unlock	(0 to 5), 1000 to 9998, 9999	9999
298	Frequency search gain	0 to 32767, 9999	9999
299	Rotation direction detection selection at restarting	0, 1, 9999	0
338	Communication operation command source	0, 1	0
339	Communication speed command source	0, 1, 2	0
340	Communication startup mode selection	0, 1, 10	0

Parameter	Name	Setting range	Initial value
342	Communication EEPROM write selection	0, 1	0
343	Communication error count	—	0
450	Second applied motor	0, 1, 9999	9999
495	Remote output selection	0, 1, 10, 11	0
496	Remote output data 1	0 to 4095	0
497	Remote output data 2	0 to 4095	0
502	Stop mode selection at communication error	0, 1, 2, 3	0
503	Maintenance timer	0 (1, 9998)	0
504	Maintenance timer alarm output set time	0 to 9998, 9999	9999
547	USB communication station number	0 to 31	0
548	USB communication check time interval	0 to 999.8s 9999	9999
549	Protocol selection	0, 1	0
550	NET mode operation command source selection	0, 2, 9999	9999
551	PU mode operation command source selection	2 to 4, 9999	9999
555	Current average time	0.1 to 1.0s	1s
556	Data output mask time	0 to 20s	0s
557	Current average value monitor signal output reference current	0 to 500A	Inverter rated current
563	Energization time carrying-over times	(0 to 65535)	0
564	Operating time carrying-over times	(0 to 65535)	0
571	Holding time at a start	0 to 10s, 9999	9999
611	Acceleration time at a restart	0 to 3600s, 9999	9999
653	Speed smoothing control	0 to 200%	0
665	Regeneration avoidance frequency gain	0 to 200%	100
800	Control method selection	20, 30	20

Parameter	Name	Setting range	Initial value
859	Torque current	0 to 500A (0 to ****), 9999 *5	9999
872 *8	Input phase loss protection selection	0, 1	1
882	Regeneration avoidance operation selection	0, 1, 2	0
883	Regeneration avoidance operation level	300 to 800V	400VDC/ 780VDC *4
885	Regeneration avoidance compensation frequency limit value	0 to 10Hz, 9999	6Hz
886	Regeneration avoidance voltage gain	0 to 200%	100%
888	Free parameter 1	0 to 9999	9999
889	Free parameter 2	0 to 9999	9999
C0 (900) *7	FM terminal calibration	—	—
C2 (902) *7	Terminal 2 frequency setting bias frequency	0 to 400Hz	0Hz
C3 (902) *7	Terminal 2 frequency setting bias	0 to 300%	0%
125 (903) *7	Terminal 2 frequency setting gain frequency	0 to 400Hz	60Hz
C4 (903) *7	Terminal 2 frequency setting gain	0 to 300%	100%
C5 (904) *7	Terminal 4 frequency setting bias frequency	0 to 400Hz	0Hz
C6 (904) *7	Terminal 4 frequency setting bias	0 to 300%	20%
126 (905) *7	Terminal 4 frequency setting gain frequency	0 to 400Hz	60Hz
C7 (905) *7	Terminal 4 frequency setting gain	0 to 300%	100%
C22 (922) *6 *7	Frequency setting voltage bias frequency (built-in potentiometer)	0 to 400Hz	0
C23 (922) *6 *7	Frequency setting voltage bias (built-in potentiometer)	0 to 300%	0

Parameter	Name	Setting range	Initial value
C24 (923) ^{*6*7}	Frequency setting voltage gain frequency (built-in potentiometer)	0 to 400Hz	60Hz
C25 (923) ^{*6*7}	Frequency setting voltage gain (built-in potentiometer)	0 to 300%	100%
990	PU buzzer control	0, 1	1
991	PU contrast adjustment	0 to 63	58
Pr.CL	Parameter clear	0, 1	0
ALLC	All parameter clear	0, 1	0
Er.CL	Faults history clear	0, 1	0
Pr.CH	Initial value change list	—	—



- *1 Differ according to capacities.
6%: 0.75K or less, 4%: 1.5-3.7K, 3%: 5.5 and 7.5K, 2%: 11 and 15K
- *2 Differ according to capacities.
5s: 3.7K or less, 10s: 5.5 and 7.5K,
15s: 11 and 15K
- *3 Differ according to capacities.
6%: 0.1 and 0.2K, 4%: 0.4-7.5K,
2%: 11 and 15K
- *4 Differ according to voltage class. (100, 200, and 400V classes)
- *5 The range differs according to the Pr. 71 setting.
- *6 Set this parameter when calibrating the operation panel built-in potentiometer for the FREQROL-E500 series operation panel (PA02) connected with cable.
- *7 The parameter number in parentheses is the one for use with the operation panel (PA02) for the FREQROL-E500 series or parameter unit (FR-PU04/FR-PU07).
- *8 Available only for the three-phase power input model.

Appendix 2 List of fault displays (FR-E700)

Fault displays significantly vary depending on model of device. The list of fault displays for the FR-E700 model is included in this document.

Make sure to read the specific manual for your device if your environment contains different devices.

Function name		Description	Corrective action	Display
Error message	Operation panel lock	Operation has been attempted during the operation panel lock.	Press  for 2s to release the lock.	<i>HOLD</i>
	Password locked	Reading/writing of a password-restricted parameter has been attempted.	Enter the password in Pr. 297 Password lock/unlock to unlock the password function before operating.	<i>LOCd</i>
	Parameter write error	<ul style="list-style-type: none"> Parameter setting has been attempted although parameter writing is set to be disabled. Overlapping range has been set for the frequency jump. PU and the inverter cannot make normal communication. 	<ul style="list-style-type: none"> Check the setting of Pr. 77 Parameter write selection. Check the settings of Pr. 31 to Pr. 36 (frequency jump). Check the connection of PU and the inverter. 	<i>Er 1</i>
	Write error during operation	Parameter writing has been attempted while a value other than "2" is set in Pr. 77 Parameter write selection and the STF (STR) is ON.	<ul style="list-style-type: none"> Set "2" in Pr.77 Parameter write selection. After stopping the operation, set parameters. 	<i>Er 2</i>
	Calibration error	Analog input bias and gain calibration values have been set too close.	Check the settings of calibration parameters C3, C4, C6 and C7 (calibration functions).	<i>Er 3</i>
	Mode designation error	<ul style="list-style-type: none"> Parameter setting has been attempted in the External or NET operation mode when Pr.77 Parameter write selection is not "2". Parameter writing has been attempted when the command source is not at the operation panel. 	<ul style="list-style-type: none"> After setting the operation mode to the "PU operation mode," set parameters. Set "2" in Pr.77 Parameter write selection. Disconnect FR Configurator (USB connector) and the parameter unit (FR-PU04/FR-PU07), then set Pr. 551 PU mode operation command source selection = "9999 (initial value)". Set Pr. 551 PU mode operation command source selection = "4". 	<i>Er 4</i>
	Inverter reset	The reset signal (RES signal) is ON. (Inverter output is shutoff.)	Turn OFF the reset command.	<i>Err.</i>

Function name		Description	Corrective action	Display
Warning	Stall prevention (overcurrent)	The overcurrent stall prevention has been activated.	<ul style="list-style-type: none"> • Increase or decrease the Pr. 0 Torque boost setting by 1% and check the motor status. • Set the acceleration/deceleration time longer. • Reduce the load. Try Advanced magnetic flux vector control or General-purpose magnetic flux vector control. • Check the peripheral devices for faults. • Adjust the Pr. 13 Starting frequency setting. Change the Pr. 14 Load pattern selection setting. • Set the stall prevention operation current in Pr. 22 Stall prevention operation level. (The acceleration/deceleration time may change.) Increase the stall prevention operation level with Pr. 22 Stall prevention operation level, or disable stall prevention with Pr. 156 Stall prevention operation selection. (Operation at OL occurrence can be selected using Pr. 156 Stall prevention operation selection.) 	OL
	Stall prevention (overvoltage)	The overvoltage stall prevention function has been activated. (This warning is also output during the regeneration avoidance operation.)	Set the deceleration time longer.	oL
	Regenerative brake prealarm*2	The regenerative brake duty has reached 85% of the Pr. 70 Special regenerative brake duty setting or higher.	<ul style="list-style-type: none"> • Set the deceleration time longer. • Check the Pr.30 Regenerative function selection and Pr. 70 Special regenerative brake duty settings. 	r b
	Electronic thermal relay function prealarm*1	The cumulative value of the electronic thermal O/L relay has reached 85% of the Pr. 9 Electronic thermal O/L relay setting or higher.	<ul style="list-style-type: none"> • Reduce the load and frequency of operation. • Set an appropriate value in Pr. 9 Electronic thermal O/L relay. 	rH
	PU stop	 on the operation panel has been pressed during the External operation.	Turn the start signal OFF and release with  .	P5
	Maintenance signal output*2	The cumulative energization time has exceeded the maintenance output timer set value.	Setting "0" in Pr. 503 Maintenance timer erases the signal.	nF
	Undervoltage	The voltage at the main circuit power has been lowered.	Investigate the devices on the power supply line such as the power supply itself.	Uu
Minor failure	Fan alarm	The cooling fan is at a standstill although it is required to be operated. The cooling fan speed has decelerated.	Check for fan failure. Please contact your sales representative.	F n

Function name		Description	Corrective action	Display
Major fault	Overcurrent trip during acceleration	Overcurrent has occurred during acceleration.	<ul style="list-style-type: none"> • Set the acceleration time longer. (Shorten the downward acceleration time in vertical lift application.) • If "E.OC1" always appears at start, disconnect the motor once and restart the inverter. If "E.OC1" still appears, the inverter may be faulty. Contact your sales representative. • Check the wiring for output short circuit and ground fault. • When the rated motor frequency is 50Hz, set the Pr. 3 Base frequency to 50Hz. • Lower the stall prevention operation level. • Activate the stall prevention operation and the fast-response current limit operation. (Pr.156) • For the operation with frequent regenerative driving, set the base voltage (rated motor voltage, etc.) in Pr. 19 Base frequency voltage. • If the motor is coasting, stop the motor, then input a start command. Alternatively, use the automatic restart after instantaneous power failure/flying start function. 	E.OC 1
	Overcurrent trip during constant speed	Overcurrent has occurred during constant speed operation.	<ul style="list-style-type: none"> • Keep the load stable. • Check the wiring to avoid output short circuit or ground fault. • Lower the stall prevention operation level. • Activate the stall prevention operation and the fast-response current limit operation. (Pr.156) 	E.OC 2
	Overcurrent trip during deceleration or stop	Overcurrent has occurred during deceleration or at a stop.	<ul style="list-style-type: none"> • Set the deceleration time longer. • Check the wiring to avoid output short circuit or ground fault. • Check if the mechanical brake is set to be activated too early. • Lower the stall prevention operation level. • Activate the stall prevention operation and the fast-response current limit operation. (Pr.156) 	E.OC 3
	Regenerative overvoltage trip during acceleration	Overvoltage has occurred during acceleration.	<ul style="list-style-type: none"> • Set the acceleration time shorter. • Use the regeneration avoidance function (Pr. 882, Pr. 883, Pr.885, Pr.886). • Set the Pr. 22 Stall prevention operation level correctly. 	E.OV 1

Function name		Description	Corrective action	Display
Major fault	Regenerative overvoltage trip during constant speed	Overvoltage has occurred during constant speed operation.	<ul style="list-style-type: none"> Keep the load stable. Use the regeneration avoidance function (Pr. 882, Pr. 883, Pr.885, Pr.886). Use the brake resistor, brake unit or power regeneration common converter (FR-CV) as required. Set the Pr. 22 Stall prevention operation level correctly. 	E.O.v2
	Regenerative overvoltage trip during deceleration or stop	Overvoltage has occurred during deceleration or at a stop.	<ul style="list-style-type: none"> Set the deceleration time longer. (Set the deceleration time which matches the moment of inertia of the load.) Make the brake cycle longer. Use the regeneration avoidance function (Pr. 882, Pr. 883, Pr.885, Pr.886). Use the brake resistor, brake unit or power regeneration common converter (FR-CV) as required. 	E.O.v3
	Inverter overload trip (electronic thermal O/L relay function)*1	The electronic thermal relay function for inverter element protection has been activated.	<ul style="list-style-type: none"> Set the acceleration/deceleration time longer. Adjust the Pr. 0 Torque boost setting. Set the Pr. 14 Load pattern selection setting according to the load pattern of the using machine. Reduce the load. Set the surrounding air temperature to within the specifications. 	E.F.HF
	Motor overload trip (electronic thermal O/L relay function)*1	The electronic thermal relay function for motor protection has been activated.	<ul style="list-style-type: none"> Reduce the load. For a constant-torque motor, set the constant-torque motor in Pr. 71 Applied motor. Set the stall prevention operation level accordingly. 	E.F.HN
	Heatsink overheat	The heatsink has overheated.	<ul style="list-style-type: none"> Set the surrounding air temperature to within the specifications. Clean the heatsink. Replace the cooling fan. 	E.F.I n
	Input phase loss*3	One of the three phases on the inverter input side has been lost. It may also appear if phase-to-phase voltage of the three-phase power input has become largely unbalanced.	<ul style="list-style-type: none"> Wire the cables properly. Repair a break portion in the cable. Check the Pr. 872 Input phase loss protection selection setting. Set Pr. 872 Input phase loss protection selection = "0" (without input phase loss protection) when three-phase input voltage is largely unbalanced. 	E.I.LF
	Stall prevention stop	The output frequency has dropped to 1Hz as a result of deceleration due to the excess motor load.	Reduce the load. (Check the Pr. 22 Stall prevention operation level setting.)	E.O.LF

Function name		Description	Corrective action	Display
Major fault	Brake transistor alarm detection	A fault has occurred in the brake circuit, such as a brake transistor breakage. (In this case, the inverter must be powered off immediately.)	Replace the inverter.	E. bE
	Output side earth (ground) fault overcurrent at start*2	An earth (ground) fault has occurred on the inverter's output side (detected only at a start).	Remedy the ground fault portion.	E. GF
	Output phase loss*3	One of the three phases (U, V, W) on the inverter's output side (load side) has been lost during inverter operation.	<ul style="list-style-type: none"> Wire the cables properly. If the motor capacity is smaller than the inverter capacity, choose the inverter and motor capacities that match. 	E. LF
	External thermal relay operation*2	The external thermal relay connected to the OH signal has been activated.	<ul style="list-style-type: none"> Reduce the load and operate less frequently. Even if the relay contacts are reset automatically, the inverter will not restart unless it is reset. 	E.OHr
	Option fault	Installation of a communication option has been attempted while the operation is restricted with the password lock (Pr. 296 Password lock level = "0 or 100").	<ul style="list-style-type: none"> To apply the password lock when installing a communication option, set Pr.296 Password lock level ≠ "0, 100". If the problem still persists after taking the above measure, contact your sales representative. 	E.OPr
	Communication option fault	A communication error has occurred on the communication line of the communication option.	<ul style="list-style-type: none"> Check the settings of the option functions. Connect the built-in option securely. Check the connections of the communication cables. Connect terminating resistors correctly. 	E.OP I
	Option fault	A fault, such as a contact fault, has occurred at the contactor of the inverter or the plug-in option. The setting of the switch on the plug-in option, which is for manufacturer setting, has been changed.	<ul style="list-style-type: none"> Connect the plug-in option securely. Take measures against noises if there are devices producing excess electrical noises around the inverter. If the situation does not improve after taking the above measure, please contact your sales representative. Set the switch on the plug-in option, which is for manufacturer setting, back to the initial setting. (Refer to the Instruction Manual of each option.) 	E. I
	Parameter storage device fault	Operation of the component where parameters are stored (control circuit board) has become abnormal.	<ul style="list-style-type: none"> Please contact your sales representative. When performing parameter writing frequently for communication purposes, set "1" in Pr. 342 Communication EEPROM write selection to enable RAM write. Note that powering OFF returns the inverter to the status before RAM write. 	E. PE

Function name		Description	Corrective action	Display
Major fault	Internal board fault	The control circuit board and the main circuit board do not match.	Please contact your sales representative. (For parts replacement, consult the nearest Mitsubishi FA Center.)	EPE2
	PU disconnection	<ul style="list-style-type: none"> A communication error has occurred between the PU and the inverter. The communication interval has exceeded the permissible time period during RS-485 communication via the PU connector. The number of communication errors has exceeded the number of retries. 	<ul style="list-style-type: none"> Connect the parameter unit cable securely. Check the communication data and communication settings. Increase the Pr. 122 PU communication check time interval setting, or set "9999" (no communication check). 	EPUE
	Retry count excess*2	Operation restart within the set number of retries has failed.	Eliminate the cause of the error preceding this alarm indication.	E.r.EF
	CPU fault	An error has occurred in the CPU and in the peripheral circuits.	<ul style="list-style-type: none"> Take measures against noises if there are devices producing excess electrical noises around the inverter. Check the connection between the terminals PC and SD. (E6/E7) If the situation does not improve after taking the above measure, please contact your sales representative. 	E. 5 E. 6 E. 7 E.CPU
	Brake sequence fault*2	A sequence error has occurred while the brake sequence function (Pr.278 to Pr.283) is valid.	Check the parameter setting and check the wiring.	E.n64 ~ E.n67
	Inrush current limit circuit fault	The resistor of the inrush current limit circuit has overheated.	Configure a circuit where frequent power ON/OFF is not repeated. If the situation does not improve after taking the above measure, please contact your sales representative.	E.I OH
	Analog input fault	A voltage (current) has been input to terminal 4 when the setting in Pr. 267 Terminal 4 input selection and the setting of voltage/current input switch are different.	Give a frequency command by a current input or set Pr.267 Terminal 4 input selection, and set the voltage/current input switch to voltage input.	E.A1 E
	USB communication fault	The communication has been broken for Pr. 548 USB communication check time interval.	<ul style="list-style-type: none"> Check the Pr.548 USB communication check time interval setting. Check the USB communication cable. Increase the Pr.548 USB communication check time interval setting, or set "9999". 	E.USB
	Internal circuit fault	An internal circuit fault has occurred.	Please contact your sales representative.	E. 13

*1 Resetting the inverter initializes the internal cumulative heat value of the electronic thermal relay function.

*2 This protective function is not available in the default state.

*3 This functions only for devices with 3-phase power input.

Appendix 3 Final assembly of training devices

STS Part 2 - This appendix describes the specifications and connection method for the training device used with this inverter training document.

Training device connection diagram

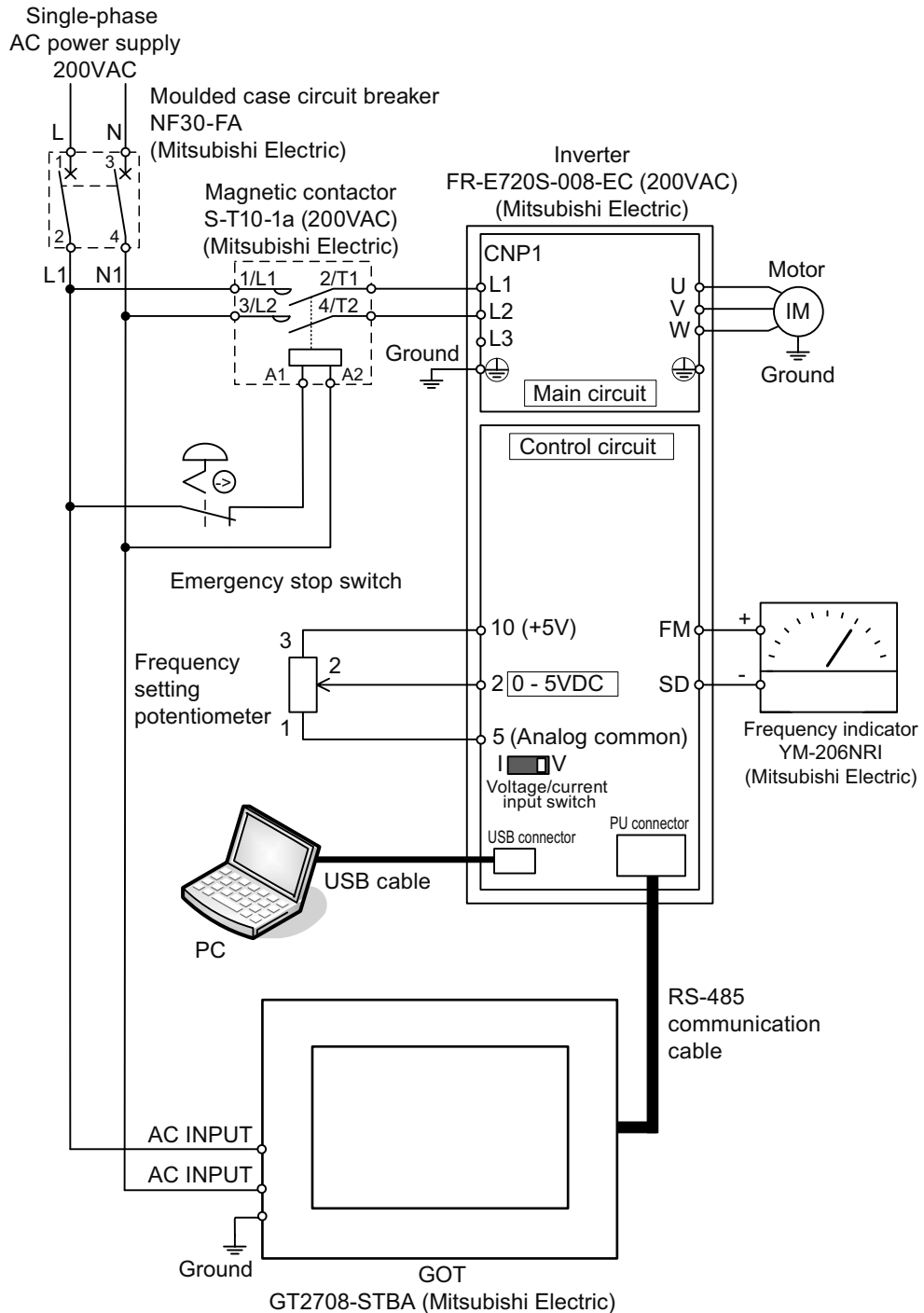

Device configuration

Inverter: Mitsubishi Electric FR-E720S-008-EC (200VAC)*1	GOT: Mitsubishi Electric GT2708-STBA (100-240VAC)
Frequency indicator: Mitsubishi Electric YM-206NRI	Moulded case circuit breaker: Mitsubishi Electric NF30-FA (2P 10A)
Magnetic contactor: Mitsubishi Electric S-T10-1a (200VAC)*2	Emergency stop button
External potentiometer	Motor: Mitsubishi Electric SF-JR 0.1kW, 4-pole

*1 Model used in Europe. Refer to the table below for the models in other regions.

*2 200V models. Use Mitsubishi Electric S-T10-1a (100VAC) for 100V models.

Inverter models for each region

Country	Voltage	Model
Europe	200V	FR-E720S-008-EC
North America	100V	FR-E710W-008-NA
India	200V	FR-E720S-008-EC
Singapore	200V	FR-E720S-0.1K (200VAC)

Training device connection procedure

- 1.** Connect the power cable (200VAC) to the primary side of the moulded case circuit breaker.
- 2.** Connect a wire between the secondary side of the moulded case circuit breaker and the primary-side terminal of the magnetic contactor.
- 3.** Connect a wire between the magnetic contactor and the emergency stop button.
- 4.** Connect a wire between the Secondary-side terminal of the magnetic contactor and the power input terminal of the inverter.
- 5.** Wire the motor to the U, V, and W output terminals of the inverter.
- 6.** Connect a wire between the external potentiometer for frequency setting to the inverter analog input terminal.
- 7.** Connect a wire between the analog output terminal of the inverter and the frequency indicator.
- 8.** Connect an RS-485 communication cable between the inverter and GOT.

Refer to Chapter 5.1 "Connecting GOT with the inverter" in this document for more information on communications settings between the inverter and GOT.

Appendix 4 Terminal connection diagram (FR-E700)

Terminal wiring diagrams significantly vary depending on model of device. This document includes the terminal wiring diagram for the Mitsubishi general-purpose inverter FR-E700 series.

Make sure to read the specific manual for your device if your environment contains different devices.

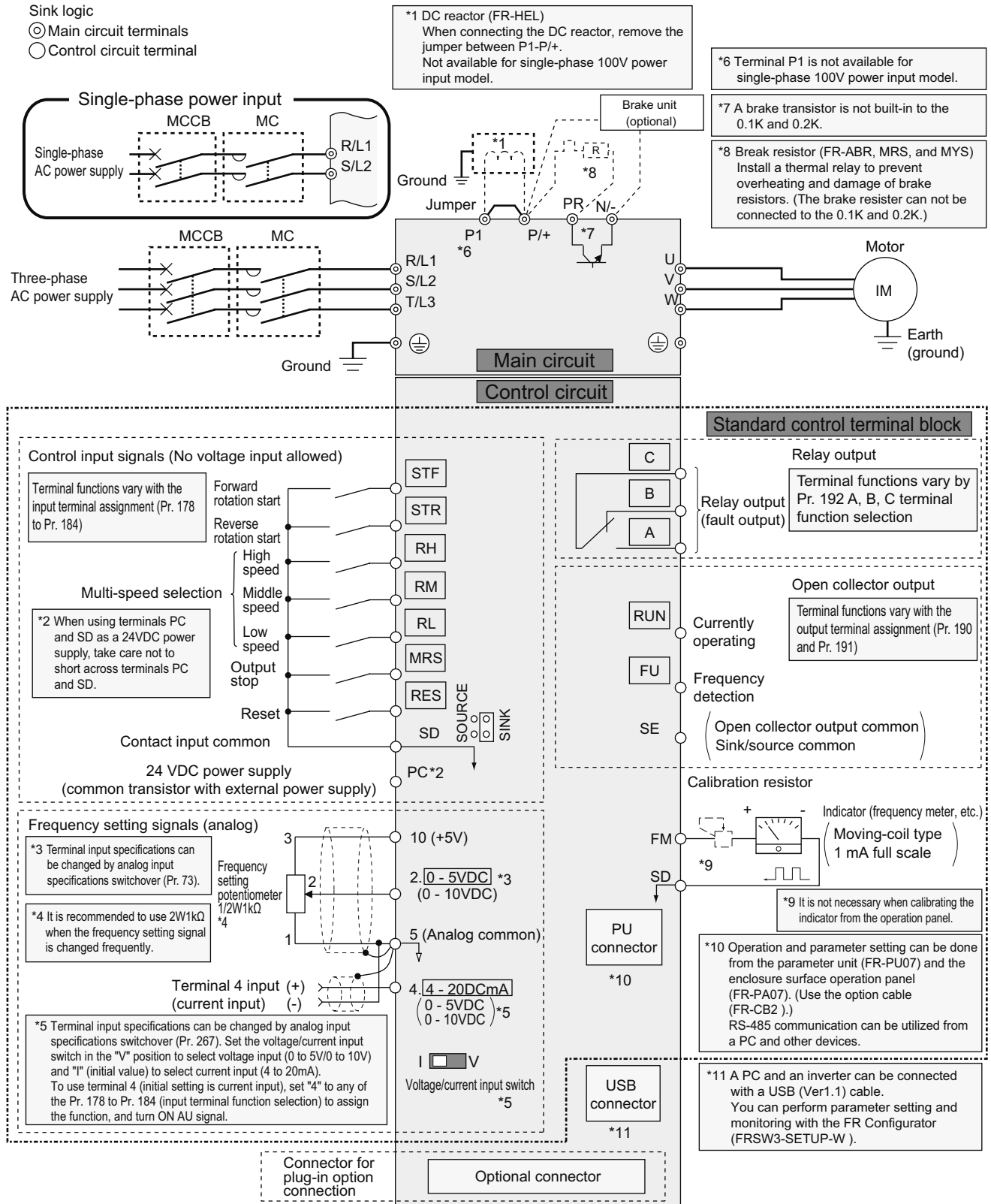

FR-E700

Source logic

- ⊙ Main circuit terminal
- Control circuit terminal

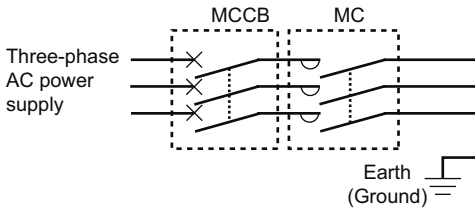
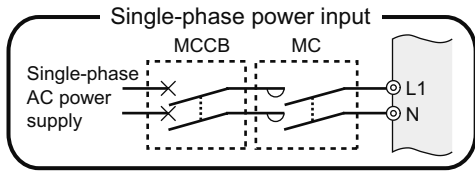

*1. DC reactor (FR-HEL)
When connecting a DC reactor, remove the jumper across P1 and P/+.

Brake unit (Option)

*6 A brake transistor is not built-in to the FR-E720S-008 and 015.

*7 Brake resistor (FR-ABR, MRS type)
Install a thermal relay to prevent an overheat and burnout of the brake resistor. (The brake resistor can not be connected to the FR-E720S-008 and 015.)

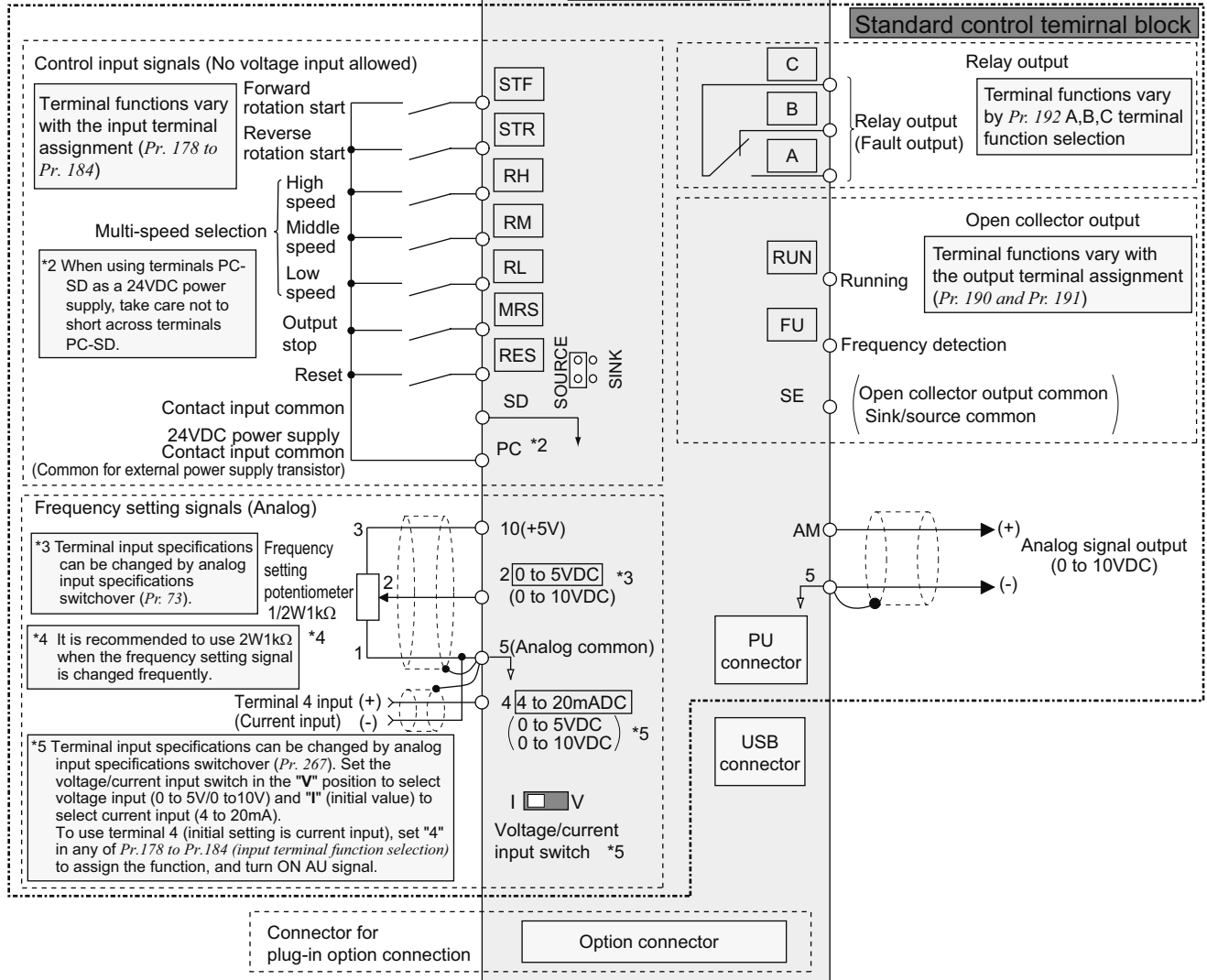
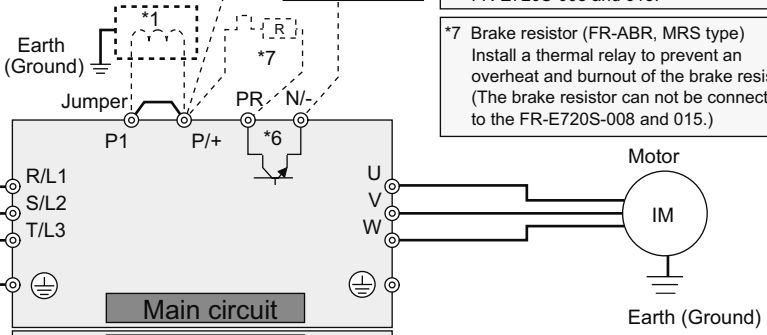

FR-E700-EC

Manual Revision History

Date of creation	Sub-number	Description
Mar. 2016	A	Initial release

mitsubishi
MITSUBISHI ELECTRIC CORPORATION

<http://Global.MitsubishiElectric.com>

HEAD OFFICE: TOKYO BLDG., 2-7-3, MARUNOUCHI, CHIYODA-KU, TOKYO 100-8310, JAPAN
